

# USER MANUAL

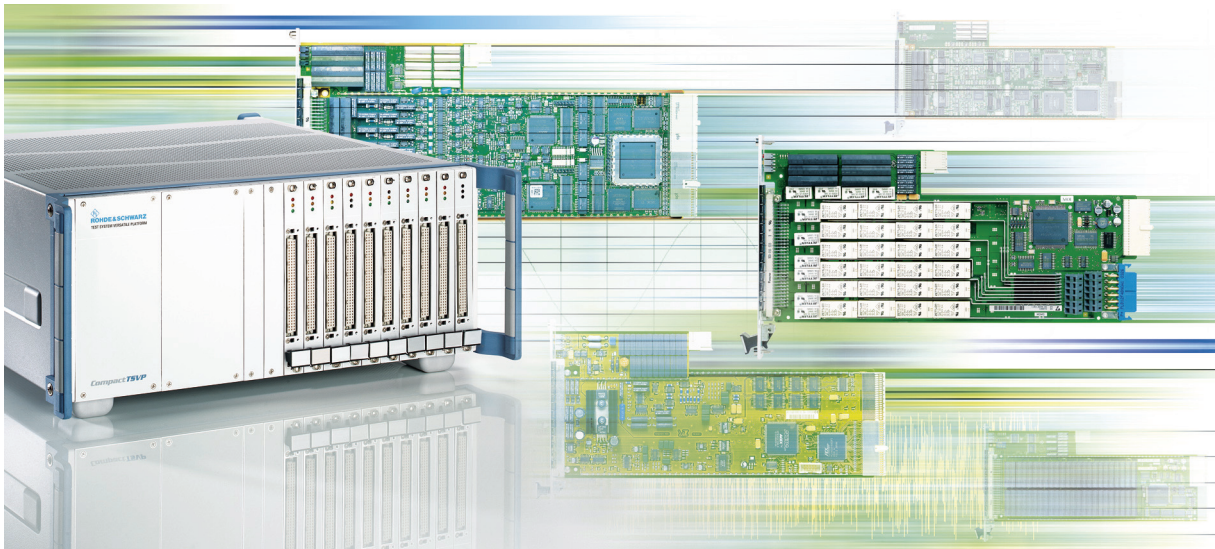

**Digital I/O Module R&S®TS-PIO3B**

**Signal Transmission Module R&S®TS-PTR**

**Rear Transmission Module R&S®TS-PRIO4**

**Port Transmission Module R&S®TS-PTRF**

**Switching Extension Module R&S®TS-PXM1**

---

## **User Manual**

2nd Issue/ 09.11 / GB 1512.3530.12

All rights, also translation into foreign languages, are reserved. No part of this manual is permitted to be reproduced in any form (print, photocopy or any other method), also not for the preparation of lectures, or processed, reproduced or made available using electronic systems without written permission from ROHDE & SCHWARZ.

® The passing on to third parties and the reproduction of this documentation, utilisation and communication of its contents is not permitted unless specifically approved. Infringements will incur claims for damages. All rights reserved in the case of the award of a patent or registration of a design.

R&S® is a registered trademark of ROHDE & SCHWARZ GmbH & Co. KG.

We draw to your attention that the names of software and hardware used in the Service Manual, and the brand names of the respective companies are, in general, the subject of protection as trademarks, or under proprietary rights, or patent law.

**ROHDE & SCHWARZ GmbH & Co. KG**

Corporate Headquarters  
Mühldorfstr. 15  
D-81671 München

Telephone: ...49 (0)89/4129-13774  
Fax: ...49 (0)89/4129-13777

# Basic Safety Instructions

## Always read through and comply with the following safety instructions!

All plants and locations of the Rohde & Schwarz group of companies make every effort to keep the safety standards of our products up to date and to offer our customers the highest possible degree of safety. Our products and the auxiliary equipment they require are designed, built and tested in accordance with the safety standards that apply in each case. Compliance with these standards is continuously monitored by our quality assurance system. The product described here has been designed, built and tested in accordance with the attached EC Certificate of Conformity and has left the manufacturer's plant in a condition fully complying with safety standards. To maintain this condition and to ensure safe operation, you must observe all instructions and warnings provided in this manual. If you have any questions regarding these safety instructions, the Rohde & Schwarz group of companies will be happy to answer them.







Furthermore, it is your responsibility to use the product in an appropriate manner. This product is designed for use solely in industrial and laboratory environments or, if expressly permitted, also in the field and must not be used in any way that may cause personal injury or property damage. You are responsible if the product is used for any intention other than its designated purpose or in disregard of the manufacturer's instructions. The manufacturer shall assume no responsibility for such use of the product.

The product is used for its designated purpose if it is used in accordance with its product documentation and within its performance limits (see data sheet, documentation, the following safety instructions). Using the product requires technical skills and a basic knowledge of English. It is therefore essential that only skilled and specialized staff or thoroughly trained personnel with the required skills be allowed to use the product. If personal safety gear is required for using Rohde & Schwarz products, this will be indicated at the appropriate place in the product documentation. Keep the basic safety instructions and the product documentation in a safe place and pass them on to the subsequent users.

Observing the safety instructions will help prevent personal injury or damage of any kind caused by dangerous situations. Therefore, carefully read through and adhere to the following safety instructions before and when using the product. It is also absolutely essential to observe the additional safety instructions on personal safety, for example, that appear in relevant parts of the product documentation. In these safety instructions, the word "product" refers to all merchandise sold and distributed by the Rohde & Schwarz group of companies, including instruments, systems and all accessories.

## Symbols and safety labels

							
Notice, general danger location Observe product documentation	Caution when handling heavy equipment	Danger of electric shock	Warning! Hot surface	PE terminal	Ground	Ground terminal	Be careful when handling electrostatic sensitive devices

					
ON/OFF supply voltage	Standby indication	Direct current (DC)	Alternating current (AC)	Direct/alternating current (DC/AC)	Device fully protected by double (reinforced) insulation

### Tags and their meaning

The following signal words are used in the product documentation in order to warn the reader about risks and dangers.



indicates a hazardous situation which, if not avoided, will result in death or serious injury.



indicates a hazardous situation which, if not avoided, could result in death or serious injury.



indicates a hazardous situation which, if not avoided, could result in minor or moderate injury.



indicates the possibility of incorrect operation which can result in damage to the product.

In the product documentation, the word ATTENTION is used synonymously.

These tags are in accordance with the standard definition for civil applications in the European Economic Area. Definitions that deviate from the standard definition may also exist in other economic areas or military applications. It is therefore essential to make sure that the tags described here are always used only in connection with the related product documentation and the related product. The use of tags in connection with unrelated products or documentation can result in misinterpretation and in personal injury or material damage.

### Operating states and operating positions

*The product may be operated only under the operating conditions and in the positions specified by the manufacturer, without the product's ventilation being obstructed. If the manufacturer's specifications are not observed, this can result in electric shock, fire and/or serious personal injury or death. Applicable local or national safety regulations and rules for the prevention of accidents must be observed in all work performed.*

1. Unless otherwise specified, the following requirements apply to Rohde & Schwarz products: predefined operating position is always with the housing floor facing down, IP protection 2X, pollution severity 2, overvoltage category 2, use only indoors, max. operating altitude 2000 m above sea level, max. transport altitude 4500 m above sea level. A tolerance of  $\pm 10\%$  shall apply to the nominal voltage and  $\pm 5\%$  to the nominal frequency.
2. Do not place the product on surfaces, vehicles, cabinets or tables that for reasons of weight or stability are unsuitable for this purpose. Always follow the manufacturer's installation instructions when installing the product and fastening it to objects or structures (e.g. walls and shelves). An installation that is not carried out as described in the product documentation could result in personal injury or death.
3. Do not place the product on heat-generating devices such as radiators or fan heaters. The ambient temperature must not exceed the maximum temperature specified in the product documentation or in the data sheet. Product overheating can cause electric shock, fire and/or serious personal injury or death.

### Electrical safety

*If the information on electrical safety is not observed either at all to the extent necessary, electric shock, fire and/or serious personal injury or death may occur.*

1. Prior to switching on the product, always ensure that the nominal voltage setting on the product matches the nominal voltage of the AC supply network. If a different voltage is to be set, the power fuse of the product may have to be changed accordingly.
2. In the case of products of safety class I with movable power cord and connector, operation is permitted only on sockets with an earthing contact and protective earth connection.
3. Intentionally breaking the protective earth connection either in the feed line or in the product itself is not permitted. Doing so can result in the danger of an electric shock from the product. If extension cords or connector strips are implemented, they must be checked on a regular basis to ensure that they are safe to use.
4. If the product does not have a power switch for disconnection from the AC supply network, the plug of the connecting cable is regarded as the disconnecting device. In such cases, always ensure that the power plug is easily reachable and accessible at all times (corresponding to the length of connecting cable, approx. 2 m). Functional or electronic switches are not suitable for providing disconnection from the AC supply network. If products without power switches are integrated into racks or systems, a disconnecting device must be provided at the system level.
5. Never use the product if the power cable is damaged. Check the power cable on a regular basis to ensure that it is in proper operating condition. By taking appropriate safety measures and carefully laying the power cable, you can ensure that the cable will not be damaged and that no one can be hurt by, for example, tripping over the cable or suffering an electric shock.
6. The product may be operated only from TN/TT supply networks fused with max. 16 A (higher fuse only after consulting with the Rohde & Schwarz group of companies).
7. Do not insert the plug into sockets that are dusty or dirty. Insert the plug firmly and all the way into the socket. Otherwise, sparks that result in fire and/or injuries may occur.
8. Do not overload any sockets, extension cords or connector strips; doing so can cause fire or electric shocks.
9. For measurements in circuits with voltages  $V_{\text{rms}} > 30 \text{ V}$ , suitable measures (e.g. appropriate measuring equipment, fusing, current limiting, electrical separation, insulation) should be taken to avoid any hazards.
10. Ensure that the connections with information technology equipment, e.g. PCs or other industrial computers, comply with the IEC60950-1/EN60950-1 or IEC61010-1/EN 61010-1 standards that apply in each case.
11. Unless expressly permitted, never remove the cover or any part of the housing while the product is in operation. Doing so will expose circuits and components and can lead to injuries, fire or damage to the product.
12. If a product is to be permanently installed, the connection between the PE terminal on site and the product's PE conductor must be made first before any other connection is made. The product may be installed and connected only by a licensed electrician.
13. For permanently installed equipment without built-in fuses, circuit breakers or similar protective devices, the supply circuit must be fused in such a way that anyone who has access to the product, as well as the product itself, is adequately protected from injury or damage.

## Basic Safety Instructions

14. Use suitable overvoltage protection to ensure that no overvoltage (such as that caused by a bolt of lightning) can reach the product. Otherwise, the person operating the product will be exposed to the danger of an electric shock.
15. Any object that is not designed to be placed in the openings of the housing must not be used for this purpose. Doing so can cause short circuits inside the product and/or electric shocks, fire or injuries.
16. Unless specified otherwise, products are not liquid-proof (see also section "Operating states and operating positions", item 1. Therefore, the equipment must be protected against penetration by liquids. If the necessary precautions are not taken, the user may suffer electric shock or the product itself may be damaged, which can also lead to personal injury.
17. Never use the product under conditions in which condensation has formed or can form in or on the product, e.g. if the product has been moved from a cold to a warm environment. Penetration by water increases the risk of electric shock.
18. Prior to cleaning the product, disconnect it completely from the power supply (e.g. AC supply network or battery). Use a soft, non-linting cloth to clean the product. Never use chemical cleaning agents such as alcohol, acetone or diluents for cellulose lacquers.

### Operation

1. Operating the products requires special training and intense concentration. Make sure that persons who use the products are physically, mentally and emotionally fit enough to do so; otherwise, injuries or material damage may occur. It is the responsibility of the employer/operator to select suitable personnel for operating the products.
2. Before you move or transport the product, read and observe the section titled "Transport".
3. As with all industrially manufactured goods, the use of substances that induce an allergic reaction (allergens) such as nickel cannot be generally excluded. If you develop an allergic reaction (such as a skin rash, frequent sneezing, red eyes or respiratory difficulties) when using a Rohde & Schwarz product, consult a physician immediately to determine the cause and to prevent health problems or stress.
4. Before you start processing the product mechanically and/or thermally, or before you take it apart, be sure to read and pay special attention to the section titled "Waste disposal", item 1.
5. Depending on the function, certain products such as RF radio equipment can produce an elevated level of electromagnetic radiation. Considering that unborn babies require increased protection, pregnant women must be protected by appropriate measures. Persons with pacemakers may also be exposed to risks from electromagnetic radiation. The employer/operator must evaluate workplaces where there is a special risk of exposure to radiation and, if necessary, take measures to avert the potential danger.
6. Should a fire occur, the product may release hazardous substances (gases, fluids, etc.) that can cause health problems. Therefore, suitable measures must be taken, e.g. protective masks and protective clothing must be worn.
7. If a laser product (e.g. a CD/DVD drive) is integrated into a Rohde & Schwarz product, absolutely no other settings or functions may be used as described in the product documentation. The objective is to prevent personal injury (e.g. due to laser beams).

### Repair and service

1. The product may be opened only by authorized, specially trained personnel. Before any work is performed on the product or before the product is opened, it must be disconnected from the AC supply network. Otherwise, personnel will be exposed to the risk of an electric shock.
2. Adjustments, replacement of parts, maintenance and repair may be performed only by electrical experts authorized by Rohde & Schwarz. Only original parts may be used for replacing parts relevant to safety (e.g. power switches, power transformers, fuses). A safety test must always be performed after parts relevant to safety have been replaced (visual inspection, PE conductor test, insulation resistance measurement, leakage current measurement, functional test). This helps ensure the continued safety of the product.

### Batteries and rechargeable batteries/cells

*If the information regarding batteries and rechargeable batteries/cells is not observed either at all or to the extent necessary, product users may be exposed to the risk of explosions, fire and/or serious personal injury, and, in some cases, death. Batteries and rechargeable batteries with alkaline electrolytes (e.g. lithium cells) must be handled in accordance with the EN 62133 standard.*

1. Cells must not be taken apart or crushed.
2. Cells or batteries must not be exposed to heat or fire. Storage in direct sunlight must be avoided. Keep cells and batteries clean and dry. Clean soiled connectors using a dry, clean cloth.
3. Cells or batteries must not be short-circuited. Cells or batteries must not be stored in a box or in a drawer where they can short-circuit each other, or where they can be short-circuited by other conductive materials. Cells and batteries must not be removed from their original packaging until they are ready to be used.
4. Keep cells and batteries out of the hands of children. If a cell or a battery has been swallowed, seek medical aid immediately.
5. Cells and batteries must not be exposed to any mechanical shocks that are stronger than permitted.
6. If a cell develops a leak, the fluid must not be allowed to come into contact with the skin or eyes. If contact occurs, wash the affected area with plenty of water and seek medical aid.
7. Improperly replacing or charging cells or batteries that contain alkaline electrolytes (e.g. lithium cells) can cause explosions. Replace cells or batteries only with the matching Rohde & Schwarz type (see parts list) in order to ensure the safety of the product.
8. Cells and batteries must be recycled and kept separate from residual waste. Rechargeable batteries and normal batteries that contain lead, mercury or cadmium are hazardous waste. Observe the national regulations regarding waste disposal and recycling.

### Transport

1. The product may be very heavy. Therefore, the product must be handled with care. In some cases, the user may require a suitable means of lifting or moving the product (e.g. with a lift-truck) to avoid back or other physical injuries.

2. Handles on the products are designed exclusively to enable personnel to transport the product. It is therefore not permissible to use handles to fasten the product to or on transport equipment such as cranes, fork lifts, wagons, etc. The user is responsible for securely fastening the products to or on the means of transport or lifting. Observe the safety regulations of the manufacturer of the means of transport or lifting. Noncompliance can result in personal injury or material damage.
3. If you use the product in a vehicle, it is the sole responsibility of the driver to drive the vehicle safely and properly. The manufacturer assumes no responsibility for accidents or collisions. Never use the product in a moving vehicle if doing so could distract the driver of the vehicle. Adequately secure the product in the vehicle to prevent injuries or other damage in the event of an accident.

### **Waste disposal**

1. If products or their components are mechanically and/or thermally processed in a manner that goes beyond their intended use, hazardous substances (heavy-metal dust such as lead, beryllium, nickel) may be released. For this reason, the product may only be disassembled by specially trained personnel. Improper disassembly may be hazardous to your health. National waste disposal regulations must be observed.
2. If handling the product releases hazardous substances or fuels that must be disposed of in a special way, e.g. coolants or engine oils that must be replenished regularly, the safety instructions of the manufacturer of the hazardous substances or fuels and the applicable regional waste disposal regulations must be observed. Also observe the relevant safety instructions in the product documentation. The improper disposal of hazardous substances or fuels can cause health problems and lead to environmental damage.

## Informaciones elementales de seguridad

### **Es imprescindible leer y observar las siguientes instrucciones e informaciones de seguridad!**

El principio del grupo de empresas Rohde & Schwarz consiste en tener nuestros productos siempre al día con los estándares de seguridad y de ofrecer a nuestros clientes el máximo grado de seguridad. Nuestros productos y todos los equipos adicionales son siempre fabricados y examinados según las normas de seguridad vigentes. Nuestro sistema de garantía de calidad controla constantemente que sean cumplidas estas normas. El presente producto ha sido fabricado y examinado según el certificado de conformidad adjunto de la UE y ha salido de nuestra planta en estado impecable según los estándares técnicos de seguridad. Para poder preservar este estado y garantizar un funcionamiento libre de peligros, el usuario deberá atenerse a todas las indicaciones, informaciones de seguridad y notas de alerta. El grupo de empresas Rohde & Schwarz está siempre a su disposición en caso de que tengan preguntas referentes a estas informaciones de seguridad.

Además queda en la responsabilidad del usuario utilizar el producto en la forma debida. Este producto está destinado exclusivamente al uso en la industria y el laboratorio o, si ha sido expresamente autorizado, para aplicaciones de campo y de ninguna manera deberá ser utilizado de modo que alguna persona/cosa pueda sufrir daño. El uso del producto fuera de sus fines definidos o sin tener en cuenta las instrucciones del fabricante queda en la responsabilidad del usuario. El fabricante no se hace en ninguna forma responsable de consecuencias a causa del mal uso del producto.









## Informaciones elementales de seguridad

Se parte del uso correcto del producto para los fines definidos si el producto es utilizado conforme a las indicaciones de la correspondiente documentación del producto y dentro del margen de rendimiento definido (ver hoja de datos, documentación, informaciones de seguridad que siguen). El uso del producto hace necesarios conocimientos técnicos y ciertos conocimientos del idioma inglés. Por eso se debe tener en cuenta que el producto solo pueda ser operado por personal especializado o personas instruidas en profundidad con las capacidades correspondientes. Si fuera necesaria indumentaria de seguridad para el uso de productos de Rohde & Schwarz, encontraría la información debida en la documentación del producto en el capítulo correspondiente. Guarde bien las informaciones de seguridad elementales, así como la documentación del producto, y entréguelas a usuarios posteriores.

Tener en cuenta las informaciones de seguridad sirve para evitar en lo posible lesiones o daños por peligros de toda clase. Por eso es imprescindible leer detalladamente y comprender por completo las siguientes informaciones de seguridad antes de usar el producto, y respetarlas durante el uso del producto. Deberán tenerse en cuenta todas las demás informaciones de seguridad, como p. ej. las referentes a la protección de personas, que encontrarán en el capítulo correspondiente de la documentación del producto y que también son de obligado cumplimiento. En las presentes informaciones de seguridad se recogen todos los objetos que distribuye el grupo de empresas Rohde & Schwarz bajo la denominación de "producto", entre ellos también aparatos, instalaciones así como toda clase de accesorios.

### Símbolos y definiciones de seguridad

							
Aviso: punto de peligro general  Observar la documentación del producto	Atención en el manejo de dispositivos de peso elevado	Peligro de choque eléctrico	Advertencia: superficie caliente	Conexión a conductor de protección	Conexión a tierra	Conexión a masa	Aviso: Cuidado en el manejo de dispositivos sensibles a la electrostática (ESD)

					
Tensión de alimentación de PUESTA EN MARCHA / PARADA	Indicación de estado de espera (Standby)	Corriente continua (DC)	Corriente alterna (AC)	Corriente continua / Corriente alterna (DC/AC)	El aparato está protegido en su totalidad por un aislamiento doble (reforzado)

## Palabras de señal y su significado

En la documentación del producto se utilizan las siguientes palabras de señal con el fin de advertir contra riesgos y peligros.



PELIGRO identifica un peligro inminente con riesgo elevado que provocará muerte o lesiones graves si no se evita.



ADVERTENCIA identifica un posible peligro con riesgo medio de provocar muerte o lesiones (graves) si no se evita.



ATENCIÓN identifica un peligro con riesgo reducido de provocar lesiones leves o moderadas si no se evita.



AVISO indica la posibilidad de utilizar mal el producto y, como consecuencia, dañarlo.

En la documentación del producto se emplea de forma sinónima el término CUIDADO.

Las palabras de señal corresponden a la definición habitual para aplicaciones civiles en el área económica europea. Pueden existir definiciones diferentes a esta definición en otras áreas económicas o en aplicaciones militares. Por eso se deberá tener en cuenta que las palabras de señal aquí descritas sean utilizadas siempre solamente en combinación con la correspondiente documentación del producto y solamente en combinación con el producto correspondiente. La utilización de las palabras de señal en combinación con productos o documentaciones que no les correspondan puede llevar a interpretaciones equivocadas y tener por consecuencia daños en personas u objetos.

## Estados operativos y posiciones de funcionamiento

*El producto solamente debe ser utilizado según lo indicado por el fabricante respecto a los estados operativos y posiciones de funcionamiento sin que se obstruya la ventilación. Si no se siguen las indicaciones del fabricante, pueden producirse choques eléctricos, incendios y/o lesiones graves con posible consecuencia de muerte. En todos los trabajos deberán ser tenidas en cuenta las normas nacionales y locales de seguridad del trabajo y de prevención de accidentes.*

1. Si no se convino de otra manera, es para los productos Rohde & Schwarz válido lo que sigue: como posición de funcionamiento se define por principio la posición con el suelo de la caja para abajo, modo de protección IP 2X, grado de suciedad 2, categoría de sobrecarga eléctrica 2, uso solamente en estancias interiores, utilización hasta 2000 m sobre el nivel del mar, transporte hasta 4500 m sobre el nivel del mar. Se aplicará una tolerancia de  $\pm 10\%$  sobre el voltaje nominal y de  $\pm 5\%$  sobre la frecuencia nominal.
2. No sitúe el producto encima de superficies, vehículos, estantes o mesas, que por sus características de peso o de estabilidad no sean aptos para él. Siga siempre las instrucciones de instalación del fabricante cuando instale y asegure el producto en objetos o estructuras (p. ej. paredes y estantes). Si se realiza la instalación de modo distinto al indicado en la documentación del producto, pueden causarse lesiones o incluso la muerte.
3. No ponga el producto sobre aparatos que generen calor (p. ej. radiadores o calefactores). La temperatura ambiente no debe superar la temperatura máxima especificada en la documentación del producto o en la hoja de datos. En caso de sobrecalentamiento del producto, pueden producirse choques eléctricos, incendios y/o lesiones graves con posible consecuencia de muerte.

## Seguridad eléctrica

*Si no se siguen (o se siguen de modo insuficiente) las indicaciones del fabricante en cuanto a seguridad eléctrica, pueden producirse choques eléctricos, incendios y/o lesiones graves con posible consecuencia de muerte.*

1. Antes de la puesta en marcha del producto se deberá comprobar siempre que la tensión preseleccionada en el producto coincida con la de la red de alimentación eléctrica. Si es necesario modificar el ajuste de tensión, también se deberán cambiar en caso dado los fusibles correspondientes del producto.
2. Los productos de la clase de protección I con alimentación móvil y enchufe individual solamente podrán enchufarse a tomas de corriente con contacto de seguridad y con conductor de protección conectado.
3. Queda prohibida la interrupción intencionada del conductor de protección, tanto en la toma de corriente como en el mismo producto. La interrupción puede tener como consecuencia el riesgo de que el producto sea fuente de choques eléctricos. Si se utilizan cables alargadores o regletas de enchufe, deberá garantizarse la realización de un examen regular de los mismos en cuanto a su estado técnico de seguridad.
4. Si el producto no está equipado con un interruptor para desconectarlo de la red, se deberá considerar el enchufe del cable de conexión como interruptor. En estos casos se deberá asegurar que el enchufe siempre sea de fácil acceso (de acuerdo con la longitud del cable de conexión, aproximadamente 2 m). Los interruptores de función o electrónicos no son aptos para el corte de la red eléctrica. Si los productos sin interruptor están integrados en bastidores o instalaciones, se deberá colocar el interruptor en el nivel de la instalación.
5. No utilice nunca el producto si está dañado el cable de conexión a red. Compruebe regularmente el correcto estado de los cables de conexión a red. Asegúrese, mediante las medidas de protección y de instalación adecuadas, de que el cable de conexión a red no pueda ser dañado o de que nadie pueda ser dañado por él, p. ej. al tropezar o por un choque eléctrico.
6. Solamente está permitido el funcionamiento en redes de alimentación TN/TT aseguradas con fusibles de 16 A como máximo (utilización de fusibles de mayor amperaje solo previa consulta con el grupo de empresas Rohde & Schwarz).
7. Nunca conecte el enchufe en tomas de corriente sucias o llenas de polvo. Introduzca el enchufe por completo y fuertemente en la toma de corriente. La no observación de estas medidas puede provocar chispas, fuego y/o lesiones.
8. No sobrecargue las tomas de corriente, los cables alargadores o las regletas de enchufe ya que esto podría causar fuego o choques eléctricos.
9. En las mediciones en circuitos de corriente con una tensión  $U_{\text{eff}} > 30 \text{ V}$  se deberán tomar las medidas apropiadas para impedir cualquier peligro (p. ej. medios de medición adecuados, seguros, limitación de tensión, corte protector, aislamiento etc.).
10. Para la conexión con dispositivos informáticos como un PC o un ordenador industrial, debe comprobarse que éstos cumplan los estándares IEC60950-1/EN60950-1 o IEC61010-1/EN 61010-1 válidos en cada caso.
11. A menos que esté permitido expresamente, no retire nunca la tapa ni componentes de la carcasa mientras el producto esté en servicio. Esto pone a descubierto los cables y componentes eléctricos y puede causar lesiones, fuego o daños en el producto.

12. Si un producto se instala en un lugar fijo, se deberá primero conectar el conductor de protección fijo con el conductor de protección del producto antes de hacer cualquier otra conexión. La instalación y la conexión deberán ser efectuadas por un electricista especializado.
13. En el caso de dispositivos fijos que no estén provistos de fusibles, interruptor automático ni otros mecanismos de seguridad similares, el circuito de alimentación debe estar protegido de modo que todas las personas que puedan acceder al producto, así como el producto mismo, estén a salvo de posibles daños.
14. Todo producto debe estar protegido contra sobretensión (debida p. ej. a una caída del rayo) mediante los correspondientes sistemas de protección. Si no, el personal que lo utilice quedará expuesto al peligro de choque eléctrico.
15. No debe introducirse en los orificios de la caja del aparato ningún objeto que no esté destinado a ello. Esto puede producir cortocircuitos en el producto y/o puede causar choques eléctricos, fuego o lesiones.
16. Salvo indicación contraria, los productos no están impermeabilizados (ver también el capítulo "Estados operativos y posiciones de funcionamiento", punto 1). Por eso es necesario tomar las medidas necesarias para evitar la entrada de líquidos. En caso contrario, existe peligro de choque eléctrico para el usuario o de daños en el producto, que también pueden redundar en peligro para las personas.
17. No utilice el producto en condiciones en las que pueda producirse o ya se hayan producido condensaciones sobre el producto o en el interior de éste, como p. ej. al desplazarlo de un lugar frío a otro caliente. La entrada de agua aumenta el riesgo de choque eléctrico.
18. Antes de la limpieza, desconecte por completo el producto de la alimentación de tensión (p. ej. red de alimentación o batería). Realice la limpieza de los aparatos con un paño suave, que no se deshilache. No utilice bajo ningún concepto productos de limpieza químicos como alcohol, acetona o diluyentes para lacas nitrocelulósicas.

## Funcionamiento

1. El uso del producto requiere instrucciones especiales y una alta concentración durante el manejo. Debe asegurarse que las personas que manejen el producto estén a la altura de los requerimientos necesarios en cuanto a aptitudes físicas, psíquicas y emocionales, ya que de otra manera no se pueden excluir lesiones o daños de objetos. El empresario u operador es responsable de seleccionar el personal usuario apto para el manejo del producto.
2. Antes de desplazar o transportar el producto, lea y tenga en cuenta el capítulo "Transporte".
3. Como con todo producto de fabricación industrial no puede quedar excluida en general la posibilidad de que se produzcan alergias provocadas por algunos materiales empleados, los llamados alérgenos (p. ej. el níquel). Si durante el manejo de productos Rohde & Schwarz se producen reacciones alérgicas, como p. ej. irritaciones cutáneas, estornudos continuos, enrojecimiento de la conjuntiva o dificultades respiratorias, debe avisarse inmediatamente a un médico para investigar las causas y evitar cualquier molestia o daño a la salud.
4. Antes de la manipulación mecánica y/o térmica o el desmontaje del producto, debe tenerse en cuenta imprescindiblemente el capítulo "Eliminación", punto 1.

5. Ciertos productos, como p. ej. las instalaciones de radiocomunicación RF, pueden a causa de su función natural, emitir una radiación electromagnética aumentada. Deben tomarse todas las medidas necesarias para la protección de las mujeres embarazadas. También las personas con marcapasos pueden correr peligro a causa de la radiación electromagnética. El empresario/operador tiene la obligación de evaluar y señalar las áreas de trabajo en las que exista un riesgo elevado de exposición a radiaciones.
6. Tenga en cuenta que en caso de incendio pueden desprenderse del producto sustancias tóxicas (gases, líquidos etc.) que pueden generar daños a la salud. Por eso, en caso de incendio deben usarse medidas adecuadas, como p. ej. máscaras antigás e indumentaria de protección.
7. En caso de que un producto Rohde & Schwarz contenga un producto láser (p. ej. un lector de CD/DVD), no debe usarse ninguna otra configuración o función aparte de las descritas en la documentación del producto, a fin de evitar lesiones (p. ej. debidas a irradiación láser).

### **Reparación y mantenimiento**

1. El producto solamente debe ser abierto por personal especializado con autorización para ello. Antes de manipular el producto o abrirlo, es obligatorio desconectarlo de la tensión de alimentación, para evitar toda posibilidad de choque eléctrico.
2. El ajuste, el cambio de partes, el mantenimiento y la reparación deberán ser efectuadas solamente por electricistas autorizados por Rohde & Schwarz. Si se reponen partes con importancia para los aspectos de seguridad (p. ej. el enchufe, los transformadores o los fusibles), solamente podrán ser sustituidos por partes originales. Después de cada cambio de partes relevantes para la seguridad deberá realizarse un control de seguridad (control a primera vista, control del conductor de protección, medición de resistencia de aislamiento, medición de la corriente de fuga, control de funcionamiento). Con esto queda garantizada la seguridad del producto.

### **Baterías y acumuladores o celdas**

*Si no se siguen (o se siguen de modo insuficiente) las indicaciones en cuanto a las baterías y acumuladores o celdas, pueden producirse explosiones, incendios y/o lesiones graves con posible consecuencia de muerte. El manejo de baterías y acumuladores con electrolitos alcalinos (p. ej. celdas de litio) debe seguir el estándar EN 62133.*

1. No deben desmontarse, abrirse ni triturarse las celdas.
2. Las celdas o baterías no deben someterse a calor ni fuego. Debe evitarse el almacenamiento a la luz directa del sol. Las celdas y baterías deben mantenerse limpias y secas. Limpiar las conexiones sucias con un paño seco y limpio.
3. Las celdas o baterías no deben cortocircuitarse. Es peligroso almacenar las celdas o baterías en estuches o cajones en cuyo interior puedan cortocircuitarse por contacto recíproco o por contacto con otros materiales conductores. No deben extraerse las celdas o baterías de sus embalajes originales hasta el momento en que vayan a utilizarse.
4. Mantener baterías y celdas fuera del alcance de los niños. En caso de ingestión de una celda o batería, avisar inmediatamente a un médico.
5. Las celdas o baterías no deben someterse a impactos mecánicos fuertes indebidos.

## Informaciones elementales de seguridad

6. En caso de falta de estanqueidad de una celda, el líquido vertido no debe entrar en contacto con la piel ni los ojos. Si se produce contacto, lavar con agua abundante la zona afectada y avisar a un médico.
7. En caso de cambio o recarga inadecuados, las celdas o baterías que contienen electrolitos alcalinos (p. ej. las celdas de litio) pueden explotar. Para garantizar la seguridad del producto, las celdas o baterías solo deben ser sustituidas por el tipo Rohde & Schwarz correspondiente (ver lista de recambios).
8. Las baterías y celdas deben reciclarse y no deben tirarse a la basura doméstica. Las baterías o acumuladores que contienen plomo, mercurio o cadmio deben tratarse como residuos especiales. Respete en esta relación las normas nacionales de eliminación y reciclaje.

### Transporte

1. El producto puede tener un peso elevado. Por eso es necesario desplazarlo o transportarlo con precaución y, si es necesario, usando un sistema de elevación adecuado (p. ej. una carretilla elevadora), a fin de evitar lesiones en la espalda u otros daños personales.
2. Las asas instaladas en los productos sirven solamente de ayuda para el transporte del producto por personas. Por eso no está permitido utilizar las asas para la sujeción en o sobre medios de transporte como p. ej. grúas, carretillas elevadoras de horquilla, carros etc. Es responsabilidad suya fijar los productos de manera segura a los medios de transporte o elevación. Para evitar daños personales o daños en el producto, siga las instrucciones de seguridad del fabricante del medio de transporte o elevación utilizado.
3. Si se utiliza el producto dentro de un vehículo, recae de manera exclusiva en el conductor la responsabilidad de conducir el vehículo de manera segura y adecuada. El fabricante no asumirá ninguna responsabilidad por accidentes o colisiones. No utilice nunca el producto dentro de un vehículo en movimiento si esto pudiera distraer al conductor. Asegure el producto dentro del vehículo debidamente para evitar, en caso de un accidente, lesiones u otra clase de daños.

### Eliminación

1. Si se trabaja de manera mecánica y/o térmica cualquier producto o componente más allá del funcionamiento previsto, pueden liberarse sustancias peligrosas (polvos con contenido de metales pesados como p. ej. plomo, berilio o níquel). Por eso el producto solo debe ser desmontado por personal especializado con formación adecuada. Un desmontaje inadecuado puede ocasionar daños para la salud. Se deben tener en cuenta las directivas nacionales referentes a la eliminación de residuos.
2. En caso de que durante el trato del producto se formen sustancias peligrosas o combustibles que deban tratarse como residuos especiales (p. ej. refrigerantes o aceites de motor con intervalos de cambio definidos), deben tenerse en cuenta las indicaciones de seguridad del fabricante de dichas sustancias y las normas regionales de eliminación de residuos. Tenga en cuenta también en caso necesario las indicaciones de seguridad especiales contenidas en la documentación del producto. La eliminación incorrecta de sustancias peligrosas o combustibles puede causar daños a la salud o daños al medio ambiente.

## **Additional safety instructions:**

- Any alteration to the basic equipment is prohibited, unless carried out by R&S authorized persons.
- In case that a module is inserted which is specified for an analog bus operation < 60 VDC, then this limit is also restrictively valid for the total system.
- The voltage limits for exposed voltage-carrying parts under DIN EN61010-1/6.3 must on no account be exceeded.  
If the use of higher voltages is required, this may be done only after consultation with R&S.
- The total power which may be drawn from the secondary side depends on the format of the relevant backplane segment (typically 250VA).
- When installing in racks, the ventilation of the system must be such that the specified data sheet values of 0 ... 50 °C are adhered to.





# Qualitätszertifikat

## Certificate of quality

## Certificat de qualité

Certified Quality System  
**ISO 9001**

Certified Environmental System  
**ISO 14001**

### **Sehr geehrter Kunde,**

Sie haben sich für den Kauf eines Rohde&Schwarz-Produktes entschieden. Hiermit erhalten Sie ein nach modernsten Fertigungsmethoden hergestelltes Produkt. Es wurde nach den Regeln unseres Qualitätsmanagementsystems entwickelt, gefertigt und geprüft. Das Rohde&Schwarz-Qualitätsmanagementsystem ist u.a. nach ISO9001 und ISO14001 zertifiziert.

### **Der Umwelt verpflichtet**

- ▮ Energie-effiziente, RoHS-konforme Produkte
- ▮ Kontinuierliche Weiterentwicklung nachhaltiger Umweltkonzepte
- ▮ ISO 14001-zertifiziertes Umweltmanagementsystem

### **Dear Customer,**

You have decided to buy a Rohde&Schwarz product. You are thus assured of receiving a product that is manufactured using the most modern methods available. This product was developed, manufactured and tested in compliance with our quality management system standards. The Rohde&Schwarz quality management system is certified according to standards such as ISO9001 and ISO14001.

### **Environmental commitment**

- ▮ Energy-efficient products
- ▮ Continuous improvement in environmental sustainability
- ▮ ISO 14001-certified environmental management system

### **Cher client,**

Vous avez choisi d'acheter un produit Rohde&Schwarz. Vous disposez donc d'un produit fabriqué d'après les méthodes les plus avancées. Le développement, la fabrication et les tests respectent nos normes de gestion qualité. Le système de gestion qualité de Rohde&Schwarz a été homologué, entre autres, conformément aux normes ISO9001 et ISO14001.

### **Engagement écologique**

- ▮ Produits à efficience énergétique
- ▮ Amélioration continue de la durabilité environnementale
- ▮ Système de gestion de l'environnement certifié selon ISO 14001



## Address List

### Headquarters, Plants and Subsidiaries

#### Headquarters

ROHDE & SCHWARZ GmbH & Co. KG  
Mühlendorfstraße 15 · D-81671 München  
P.O.Box 80 14 69 · D-81614 München

Phone +49 (89) 41 29-0  
Fax +49 (89) 41 29-121 64  
[info.rs@rohde-schwarz.com](mailto:info.rs@rohde-schwarz.com)

#### Plants

ROHDE & SCHWARZ Messgerätebau GmbH  
Riedbachstraße 58 · D-87700 Memmingen  
P.O.Box 16 52 · D-87686 Memmingen

Phone +49 (83 31) 1 08-0  
+49 (83 31) 1 08-1124  
[info.rsmb@rohde-schwarz.com](mailto:info.rsmb@rohde-schwarz.com)

ROHDE & SCHWARZ GmbH & Co. KG  
Werk Teisnach  
Kaikenrieder Straße 27 · D-94244 Teisnach  
P.O.Box 11 49 · D-94240 Teisnach

Phone +49 (99 23) 8 50-0  
Fax +49 (99 23) 8 50-174  
[info.rsdt@rohde-schwarz.com](mailto:info.rsdt@rohde-schwarz.com)

ROHDE & SCHWARZ závod  
Vimperk, s.r.o.  
Location Spidrova 49  
CZ-38501 Vimperk

Phone +420 (388) 45 21 09  
Fax +420 (388) 45 21 13

ROHDE & SCHWARZ GmbH & Co. KG  
Dienstleistungszentrum Köln  
Graf-Zeppelin-Straße 18 · D-51147 Köln  
P.O.Box 98 02 60 · D-51130 Köln

Phone +49 (22 03) 49-0  
Fax +49 (22 03) 49 51-229  
[info.rsd@rohde-schwarz.com](mailto:info.rsd@rohde-schwarz.com)  
[service.rsd@rohde-schwarz.com](mailto:service.rsd@rohde-schwarz.com)

#### Subsidiaries

R&S BICK Mobilfunk GmbH  
Fritz-Hahne-Str. 7 · D-31848 Bad Münder  
P.O.Box 20 02 · D-31844 Bad Münder

Phone +49 (50 42) 9 98-0  
Fax +49 (50 42) 9 98-105  
[info.bick@rohde-schwarz.com](mailto:info.bick@rohde-schwarz.com)

ROHDE & SCHWARZ FTK GmbH  
Wendenschloßstraße 168, Haus 28  
D-12557 Berlin

Phone +49 (30) 658 91-122  
Fax +49 (30) 655 50-221  
[info.ftk@rohde-schwarz.com](mailto:info.ftk@rohde-schwarz.com)

ROHDE & SCHWARZ SIT GmbH  
Am Studio 3  
D-12489 Berlin

Phone +49 (30) 658 84-0  
Fax +49 (30) 658 84-183  
[info.sit@rohde-schwarz.com](mailto:info.sit@rohde-schwarz.com)

R&S Systems GmbH  
Graf-Zeppelin-Straße 18  
D-51147 Köln

Phone +49 (22 03) 49-5 23 25  
Fax +49 (22 03) 49-5 23 36  
[info.rssys@rohde-schwarz.com](mailto:info.rssys@rohde-schwarz.com)

GEDIS GmbH  
Sophienblatt 100  
D-24114 Kiel

Phone +49 (431) 600 51-0  
Fax +49 (431) 600 51-11  
[sales@gedis-online.de](mailto:sales@gedis-online.de)

HAMEG Instruments GmbH  
Industriestraße 6  
D-63533 Mainhausen

Phone +49 (61 82) 800-0  
Fax +49 (61 82) 800-100  
[info@hameg.de](mailto:info@hameg.de)

### Locations Worldwide

Please refer to our homepage: [www.rohde-schwarz.com](http://www.rohde-schwarz.com)

- ◆ Sales Locations
- ◆ Service Locations
- ◆ National Websites



# Customer Support

## Technical support – where and when you need it

For quick, expert help with any Rohde & Schwarz equipment, contact one of our Customer Support Centers. A team of highly qualified engineers provides telephone support and will work with you to find a solution to your query on any aspect of the operation, programming or applications of Rohde & Schwarz equipment.

## Up-to-date information and upgrades

To keep your instrument up-to-date and to be informed about new application notes related to your instrument, please send an e-mail to the Customer Support Center stating your instrument and your wish. We will take care that you will get the right information.

### Europe, Africa, Middle East

Phone +49 89 4129 12345  
[customersupport@rohde-schwarz.com](mailto:customersupport@rohde-schwarz.com)

### North America

Phone 1-888-TEST-RSA (1-888-837-8772)  
[customer.support@rsa.rohde-schwarz.com](mailto:customer.support@rsa.rohde-schwarz.com)

### Latin America

Phone +1-410-910-7988  
[customersupport.la@rohde-schwarz.com](mailto:customersupport.la@rohde-schwarz.com)

### Asia/Pacific

Phone +65 65 13 04 88  
[customersupport.asia@rohde-schwarz.com](mailto:customersupport.asia@rohde-schwarz.com)

### China

Phone +86-800-810-8228 /  
+86-400-650-5896  
[customersupport.china@rohde-schwarz.com](mailto:customersupport.china@rohde-schwarz.com)





# Content

<b>1</b>	<b>Introduction</b>	<b>1-1</b>
	1.1 General	1-1
	1.2 Overview	1-2
<b>2</b>	<b>R&amp;S TS-PIO3B</b>	<b>2-1</b>
	2.1 General	2-1
	2.2 Features	2-1
	2.3 View	2-2
	2.4 Block Diagram and Mechanical Layout	2-3
	2.5 Display Elements of the Module	2-3
	2.6 Functional Description	2-4
	2.6.1 Open Drain I/O Ports	2-4
	2.6.2 TTL Port	2-5
	2.6.3 Analogue Inputs	2-6
	2.6.4 SPI	2-7
	2.6.5 Voltage Sources	2-8
	2.6.6 Other Interface Signals	2-8
	2.7 Interface Description	2-10
	2.7.1 X10 Connector on the Front	2-10
	2.7.2 PXI Bus connector X1	2-12
	2.7.3 PXI Bus connector X20	2-14
	2.7.4 X40 connector	2-16
<b>3</b>	<b>R&amp;S TS-PTR</b>	<b>3-1</b>
	3.1 General	3-1
	3.2 Features	3-1
	3.3 View	3-2
	3.4 Block Diagram and Mechanical Layout	3-2
	3.5 Display Elements of the Module	3-3
	3.6 Functional Description	3-3
	3.6.1 Passive Wiring	3-3
	3.6.2 Voltage Sources	3-4
	3.7 Interface Description	3-5



	3.7.1	X10 Connector on the Front	3-5
	3.7.2	PXI Bus connector X20	3-7
<b>4</b>		<b>R&amp;S TS-PRIO4</b>	<b>4-1</b>
	4.1	General	4-1
	4.2	Features	4-1
	4.3	View	4-1
	4.4	Block Diagram and Mechanical Layout	4-2
	4.5	Display Elements of the Module	4-2
	4.6	Functional Description	4-3
	4.6.1	Passive Wiring	4-3
	4.7	Interface Description	4-3
	4.7.1	PXI Bus connector X20	4-3
	4.7.2	Rear connector X34	4-5
	4.7.3	Jumpers	4-6
<b>5</b>		<b>R&amp;S TS-PTRF</b>	<b>5-1</b>
	5.1	General	5-1
	5.2	Features	5-1
	5.3	View	5-2
	5.4	Block Diagram	5-3
	5.5	Mechanical Layout	5-4
	5.6	Display Elements of the Module	5-5
	5.7	Functional Description	5-5
	5.7.1	Wiring of the open drain I/O ports and the analogue inputs of the R&S TS-PIO3B	5-5
	5.7.2	Function of port P9.TIO of the R&S TS-PIO3B	5-7
	5.7.3	SPI	5-7
	5.7.4	+5 V / +12 V Voltages	5-9
	5.7.5	Analogue Bus Access	5-9
	5.8	Interface Description	5-10
	5.8.1	X10 Connector on the Front	5-10
	5.8.2	Internal X20 connector	5-12
	5.8.3	Internal X33 connector	5-14
	5.8.4	Internal X34 connector	5-15
	5.8.5	Internal X35 connector	5-16
	5.8.6	Internal X36 connector	5-17



5.8.7	Internal X37 connector	5-18
5.8.8	Internal X38 connector	5-19
5.8.9	Internal X39 connector	5-20
5.8.10	Internal X40 connector	5-21
5.8.11	Internal X1 connector	5-22
5.8.12	Internal X2 connector	5-23
5.8.13	Internal X3 connector	5-24
5.8.14	Internal X4 connector	5-25
5.8.15	Internal X5 connector	5-26
5.8.16	Internal X6 connector	5-27
5.8.17	Internal X7 connector	5-28
5.8.18	Internal X8 connector	5-29
5.8.19	Internal X9 connector	5-30
5.8.20	Internal X41 connector	5-31
5.8.21	Internal X42 connector	5-32
5.8.22	Internal X32 connector	5-33
5.8.23	Internal X30 connector	5-34
<b>6</b>	<b>R&amp;S TS-PXM1</b>	<b>6-1</b>
6.1	General	6-1
6.2	Features	6-1
6.3	View	6-2
6.4	Block Diagram	6-3
6.5	Mechanical Layout	6-5
6.6	Display Elements of the Module	6-6
6.7	Functional Description	6-6
6.7.1	Relay Wiring	6-6
6.7.2	EEPROM	6-7
6.8	Interface Description	6-8
6.8.1	X10 Connector on the Front	6-8
6.8.2	Control: connector X33	6-10
6.8.3	Connectors X34 to X37	6-11
<b>7</b>	<b>Application Examples</b>	<b>7-1</b>
7.1	Control of Relays / Pneumatic Valves / Vacuum Valves	7-1
7.2	Adapter Identification	7-2
7.2.1	Parallel Adapter Identification via Ports	7-2
7.2.2	Serial Adapter Identification via SPI-EEPROM	7-2



<b>8</b>	<b>Installation of the Modules</b>	<b>8-1</b>
8.1	Installation of R&S TS-PIO3B and R&S TS-PTR	8-1
8.2	Installation of the R&S TS-PRIO4	8-2
8.3	Installation of the R&S TS-PTRF	8-3
8.4	Installation of the R&S TS-PXM1	8-4
<b>9</b>	<b>Software</b>	<b>9-1</b>
9.1	Driver Software	9-1
9.2	Soft Panel	9-2
9.3	Sample Programs	9-3
9.3.1	Programming with GTSL Libraries	9-3
9.4	Programming with Device Drivers	9-6
<b>10</b>	<b>Self-Test</b>	<b>10-1</b>
10.1	LED test	10-1
10.2	Automatic Detection	10-1
10.3	Fuse test	10-2
<b>11</b>	<b>Specifications</b>	<b>11-1</b>

# Figures

<b>Figure 1-1</b>	<b>Example configuration of the modules in an R&amp;S TSVP .....</b>	<b>1-4</b>
<b>Figure 2-1</b>	<b>View of the digital I/O module R&amp;S TS-PIO3B .....</b>	<b>2-2</b>
<b>Figure 2-2</b>	<b>Simplified diagram and mechanical structure of the R&amp;S TS-PIO3B.....</b>	<b>2-3</b>
<b>Figure 2-3</b>	<b>Wiring of the open drain I/O ports.....</b>	<b>2-4</b>
<b>Figure 2-4</b>	<b>Wiring of I/O port 9 .....</b>	<b>2-5</b>
<b>Figure 2-5</b>	<b>Wiring of the analogue inputs .....</b>	<b>2-6</b>
<b>Figure 2-6</b>	<b>Basic SPI cycle (8 bits).....</b>	<b>2-7</b>
<b>Figure 2-7</b>	<b>Wiring of the INH signal .....</b>	<b>2-9</b>
<b>Figure 2-8</b>	<b>R&amp;S TS-PIO3B X10 connector (view: plug-in side) .....</b>	<b>2-10</b>
<b>Figure 2-9</b>	<b>R&amp;S TS-PIO3B X1 connector.....</b>	<b>2-12</b>
<b>Figure 2-10</b>	<b>R&amp;S TS-PIO3B X20 connector.....</b>	<b>2-14</b>
<b>Figure 2-11</b>	<b>R&amp;S TS-PIO3B X40 connector.....</b>	<b>2-16</b>
<b>Figure 3-1</b>	<b>View of the R&amp;S TS-PTR module .....</b>	<b>3-2</b>
<b>Figure 3-2</b>	<b>Simplified diagram and mechanical structure of the R&amp;S TS-PTR .....</b>	<b>3-3</b>
<b>Figure 3-3</b>	<b>R&amp;S TS-PIO3B X10 connector (view: plug-in side) .....</b>	<b>3-5</b>
<b>Figure 3-4</b>	<b>R&amp;S TS-PIO3B X20 connector.....</b>	<b>3-7</b>
<b>Figure 4-1</b>	<b>View of the R&amp;S TS-PRIO4 module.....</b>	<b>4-1</b>
<b>Figure 4-2</b>	<b>Simplified diagram and mechanical structure of the R&amp;S TS-PRIO4 module.....</b>	<b>4-2</b>
<b>Figure 4-3</b>	<b>R&amp;S TS-PRIO4 X20 connector.....</b>	<b>4-3</b>
<b>Figure 4-4</b>	<b>R&amp;S TS-PRIO4 X34 connector.....</b>	<b>4-5</b>
<b>Figure 5-1</b>	<b>View of the R&amp;S TS-PTRF module (with R&amp;S TS-PIO3B) .....</b>	<b>5-2</b>
<b>Figure 5-2</b>	<b>Block diagram of the R&amp;S TS-PTRF .....</b>	<b>5-3</b>
<b>Figure 5-3</b>	<b>Mechanical Layout of the &amp;S TS-PTRF.....</b>	<b>5-4</b>
<b>Figure 5-4</b>	<b>Wiring of the R&amp;S TS-PIO3B ports P0 – P7 and P10 .....</b>	<b>5-6</b>
<b>Figure 5-5</b>	<b>Simplified diagram of the SPI .....</b>	<b>5-8</b>
<b>Figure 5-6</b>	<b>R&amp;S TS-PTRF X10 connector (view: plug-in side).....</b>	<b>5-10</b>
<b>Figure 5-7</b>	<b>R&amp;S TS-PTRF X20 connector (view: plug-in side).....</b>	<b>5-12</b>
<b>Figure 5-8</b>	<b>R&amp;S TS-PTRF X33 connector .....</b>	<b>5-14</b>
<b>Figure 5-9</b>	<b>R&amp;S TS-PTRF X34 connector .....</b>	<b>5-15</b>

**Figures**

<b>Figure 5-10</b>	<b>R&amp;S TS-PTRF X35 connector .....</b>	<b>5-16</b>
<b>Figure 5-11</b>	<b>R&amp;S TS-PTRF X36 connector .....</b>	<b>5-17</b>
<b>Figure 5-12</b>	<b>R&amp;S TS-PTRF X37 connector .....</b>	<b>5-18</b>
<b>Figure 5-13</b>	<b>R&amp;S TS-PTRF X38 connector .....</b>	<b>5-19</b>
<b>Figure 5-14</b>	<b>R&amp;S TS-PTRF X39 connector .....</b>	<b>5-20</b>
<b>Figure 5-15</b>	<b>R&amp;S TS-PTRF X40 connector .....</b>	<b>5-21</b>
<b>Figure 5-16</b>	<b>R&amp;S TS-PTRF X1 connector .....</b>	<b>5-22</b>
<b>Figure 5-17</b>	<b>R&amp;S TS-PTRF X2 connector .....</b>	<b>5-23</b>
<b>Figure 5-18</b>	<b>R&amp;S TS-PTRF X3 connector .....</b>	<b>5-24</b>
<b>Figure 5-19</b>	<b>R&amp;S TS-PTRF X4 connector .....</b>	<b>5-25</b>
<b>Figure 5-20</b>	<b>R&amp;S TS-PTRF X5 connector .....</b>	<b>5-26</b>
<b>Figure 5-21</b>	<b>R&amp;S TS-PTRF X6 connector .....</b>	<b>5-27</b>
<b>Figure 5-22</b>	<b>R&amp;S TS-PTRF X7 connector .....</b>	<b>5-28</b>
<b>Figure 5-23</b>	<b>R&amp;S TS-PTRF X8 connector .....</b>	<b>5-29</b>
<b>Figure 5-24</b>	<b>R&amp;S TS-PTRF X9 connector .....</b>	<b>5-30</b>
<b>Figure 5-25</b>	<b>R&amp;S TS-PTRF X41 connector .....</b>	<b>5-31</b>
<b>Figure 5-26</b>	<b>R&amp;S TS-PTRF X42 connector .....</b>	<b>5-32</b>
<b>Figure 5-27</b>	<b>R&amp;S TS-PTRF X32 connector .....</b>	<b>5-33</b>
<b>Figure 5-28</b>	<b>R&amp;S TS-PTRF X30 connector (view: plug-in side).....</b>	<b>5-34</b>
<b>Figure 6-1</b>	<b>View of the R&amp;S TS-PXM1 module .....</b>	<b>6-2</b>
<b>Figure 6-2</b>	<b>Function block diagram of the R&amp;S TS-PXM1 .....</b>	<b>6-3</b>
<b>Figure 6-3</b>	<b>R&amp;S TS-PXM1 detailed example : Relay module X34.1-X34.4 .....</b>	<b>6-4</b>
<b>Figure 6-4</b>	<b>Mechanical Layout of the R&amp;S TS-PXM1 .....</b>	<b>6-5</b>
<b>Figure 6-5</b>	<b>R&amp;S TS-PXM1 X10 connector (view from outside) .....</b>	<b>6-8</b>
<b>Figure 6-6</b>	<b>R&amp;S TS-PXM1 X33 connector .....</b>	<b>6-10</b>
<b>Figure 6-7</b>	<b>R&amp;S TS-PXM1 connectors X34 to X37 .....</b>	<b>6-11</b>
<b>Figure 7-1</b>	<b>Controlling inductive loads with R&amp;S TS-PIO3B (example) .....</b>	<b>7-1</b>
<b>Figure 7-2</b>	<b>System drawing of ATMEL AT25160 .....</b>	<b>7-3</b>
<b>Figure 9-1</b>	<b>Soft Panel of the R&amp;S TS-PIO3B .....</b>	<b>9-2</b>

# 1 Introduction

## 1.1 General

The present operating instructions provide all the information required for installing, programming and operating the following modules in the Test System Versatile Platform R&S CompactTSVP or R&S PowerTSVP:

- Digital I/O Module R&S TS-PIO3B
- Signal Transmission Module R&S TS-PTR
- Port Transmission Module R&S TS-PTRF
- Rear Transmission Module R&S TS-PRIO4
- Switching Extension Module R&S TS-PXM1

These operating instructions also provide detailed information on the special features of the modules as well as block diagrams and the pin assignment of the connectors. All the processes described in the operating instructions presume familiarity with personal computers (PCs), the Windows XP operating system and the basics in operating electrical measurement systems in the form of modules (CompactPCI or PXI modules).



## 1.2 Overview

The modules described in the present operating instructions expand the Test System Versatile Platform R&S CompactTSVP or R&S PowerTSVP by digital I/O interfaces, adapter modules and a relay card. The modules can be ordered individually.

The following list summarizes the properties and interdependencies:

### Digital I/O Module R&S TS-PIO3B

- 8 digital I/O ports of 8 bit each, open drain outputs
- 1 digital I/O port, 8 bit, TTL signal level
- 8 analogue inputs, 0-5 V, resolution of 10 bits
- External SPI interface, e.g. for adapter identification
- controlled via the CAN bus of the R&S CompactTSVP or R&S PowerTSVP
- Can be used in the backplane extension R&S TS-PXB2 (slots A1 and A2) or in any other CAN bus slot.
- Standard CompactPCI card format, reaches the front panel of the R&S CompactTSVP or R&S PowerTSVP only in connection with R&S TS-PTRF

### Signal Transmission Module R&S TS-PTR

- Feedthrough of 24 signal lines from the rear panel to the front panel
- Requires R&S TS-PRIO4 or R&S TS-PXB2.
- Standard CompactPCI card format, reaches the front panel of the R&S CompactTSVP or R&S PowerTSVP only in connection with R&S TS-PTRF

**Port Transmission Module R&S TS-PTRF**

- Adapter module for connection to R&S TS-PIO3B or R&S TS-PTR
- As many as 8 modules R&S TS-PXM... (e.g. R&S TS-PXM1) can be connected
- Optional (configurable via jumpers) feedthrough of all 8 open drain ports (64 bits) from the R&S TS-PIO3B
- Optional (configurable via jumpers) feedthrough of the 8 analogue lines of the R&S TS-PIO3B
- Optional (configurable via jumpers) external use of the SPI bus of the R&S TS-PIO3B, generation of up to 8 SPI Chip Select signals.
- External +5 V, +12 V
- Requires R&S TS-PIO3B or R&S TS-PTR

**Rear Transmission Module R&S TS-PRIO4**

- Routing of three 8-bit ports of the R&S TS-PIO3B to the TSVP rear panel.
- Requires R&S TS-PIO3B or R&S TS-PTR

**Switching Extension Module R&S TS-PXM1**

- 8 freely usable 4PDT relays(4 change over switches)
- Internal or external common connector
- Control led by one port of the R&S TS-PIO3B with R&S TS-PTRF
- Requires R&S TS-PIO3B and R&S TS-PTRF

Figure 1-1 shows various installation variants of the modules in a TSVP.

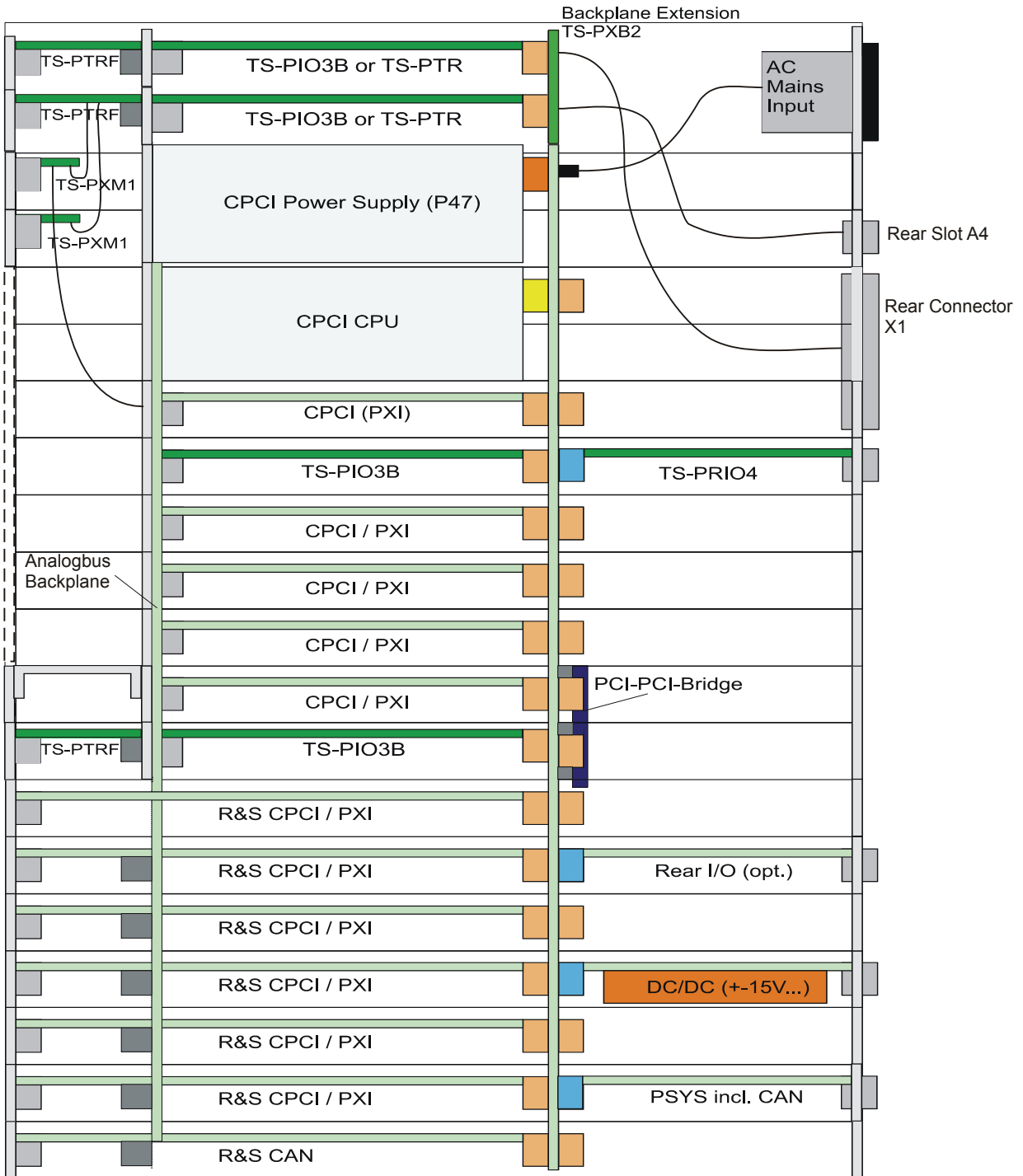

**Figure 1-1** Example configuration of the modules in an R&S TSVP



## 2 R&S TS-PIO3B

### 2.1 General

The digital I/O module R&S TS-PIO3B is a plug-in card for CAN slots of the R&S CompactTSVP or R&S PowerTSVP. The module provides digital, quasi-bidirectional lines, a TTL port, analogue inputs, SPI signals and supply voltages. All the I/O signals are referenced to earth.

The module is equipped with a separate processor and is controlled via the CAN bus.

### 2.2 Features

64 „quasi-bidirectional“ open drain I/O channels, all available on the front panel, 24 of these channels are also routed to the backplane.
8 TTL I/O channels to the front panel
8 analogue inputs on the front panel, 0-5 V signal range
Maximum current of the open drain channels 200 mA
External SPI interface
+5 V / 2 A and +12 V / 2 A fused available on the front connector
Soft panel for interactive operation
LabWindows/CVI driver available

### 2.3 View

Figure 2-1 shows the digital I/O module R&S TS-PIO3B.

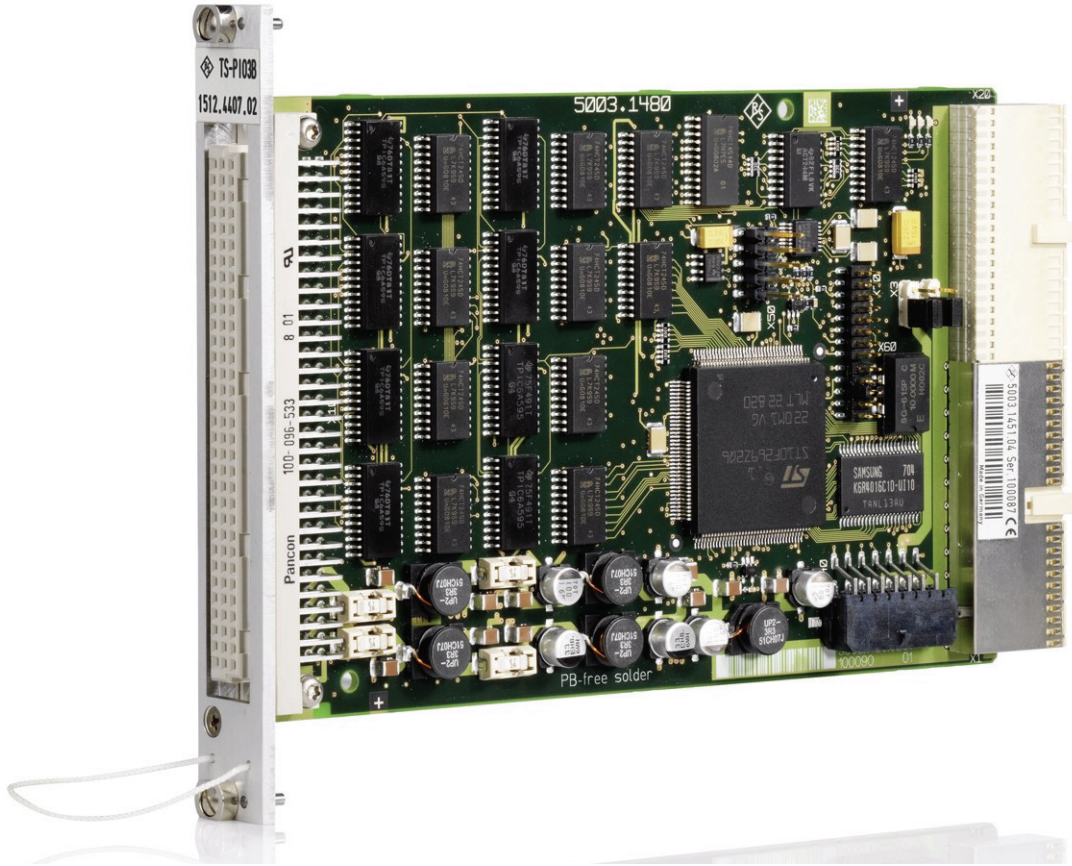
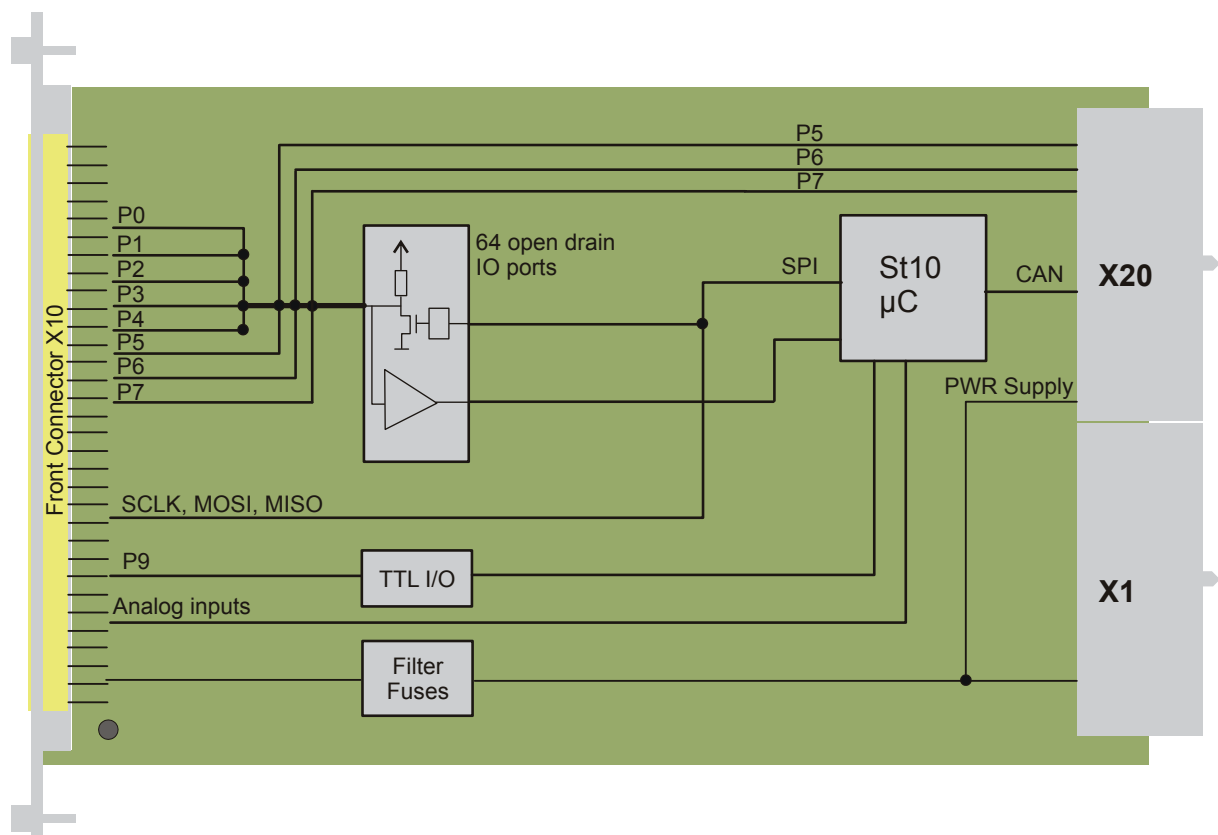

**Figure 2-1** View of the digital I/O module R&S TS-PIO3B

## 2.4 Block Diagram and Mechanical Layout

The R&S TS-PIO3B module is designed as a short plug-in card for installation on the front of the R&S CompactTSVP or R&S PowerTSVP test platforms. The X10 connector on the front either serves for the direct connection of devices under test or for connecting the R&S TS-PTRF adapter module. The X20/X1 connectors connect the module with the CompactPCI backplane/PXI control backplane.

Figure 2-2 shows the simplified diagram of the R&S TS-PIO3B module.



**Figure 2-2** Simplified diagram and mechanical structure of the R&S TS-PIO3B

## 2.5 Display Elements of the Module

The module does not feature indicators visible from the outside.

## 2.6 Functional Description

### 2.6.1 Open Drain I/O Ports

Ports 0 – 7 have a width of 8 bits each and are wired at the pin as follows:

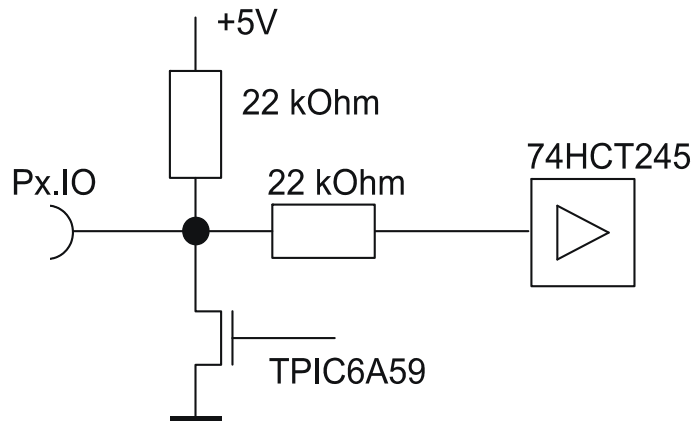

**Figure 2-3** Wiring of the open drain I/O ports

The FET shown is integrated into a Texas Instruments TPIC6A595 chip.

This wiring permits a quasi bidirectional use. A ,high' level is generated via a 22 kOhm resistor at +5 V and can be pulled to ,low' by an external source.

To switch the pin to input, the port bit is set to ,1'. In this way, the FET driver will switch off and the ,high' level on the pin is generated by the 22 kOhm pull-up resistor. Thus, the external source must sink at least 190  $\mu$ A to be recognized reliably as ,low'. This corresponds to an external resistor of maximally 4.2 kOhm.

As an output, the circuit can only drive a ,low' level actively. For this purpose, the corresponding bit is set to ,0' in the SW. The FET will then switch to a low resistance (typ. 1 Ohm) and current will flow through an external load against a positive voltage. A typical application is the switching of a relay, for example, as shown in the application examples (refer to 7.1: Control of Relays / Pneumatic Valves / Vacuum Valves).

The following function call writes an open drain I/O port :

```
ViStatus rspio3b_SetPort (
    ViSession instrumentHandle,
    ViInt32 port,
    ViUInt8 mask,
    ViUInt8 pattern);
```

The following function call reads an open drain I/O port:

```
ViStatus rspio3b_ReadPort (
    ViSession instrumentHandle,
    ViInt32 port,
    ViPUInt8 pattern);
```

Ports 4, 6 and 7 are not only available at X10 on the front but at the same time at X20 and thus connected to the backplane. Via the R&S TS-PXB2 or R&S TS-PRIO4 options, these ports can be routed to the rear panel of the R&S CompactTSVP or R&S PowerTSVP.

## 2.6.2 TTL Port

Port 9 is a digital I/O port with the following wiring per I/O pin:

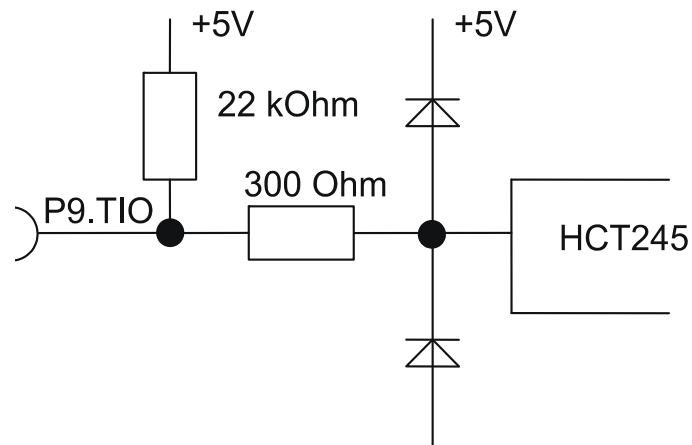

**Figure 2-4** Wiring of I/O port 9

The direction of port 9 can be switched for all port bits together.

If a R&S TS-PIO3B is plugged into X10, port 9 will no longer be available. In this case, port 9 will be used internally for generating various signals for controlling the R&S TS-PTRF.

The following function call writes port 9 (in this case, the parameter port must be set to RSPIO3B\_DIG\_PORT\_9):

```
ViStatus rspio3b_SetPort (
    ViSession instrumentHandle,
    ViInt32 port,
    ViUInt8 mask,
    ViUInt8 pattern);
```

The following function call reads port 9 (in this case, the parameter port must be set to RSPIO3B\_DIG\_PORT\_9) :

```
ViStatus rspio3b_ReadPort (
    ViSession instrumentHandle,
    ViInt32 port,
    ViPUInt8 pattern);
```

The following function call switches the direction of port 9:

```
ViStatus rspio3b_SetPortTioOutput (
    ViSession instrumentHandle,
    ViBoolean outputFlag);
```

### 2.6.3 Analogue Inputs

The analogue inputs are wired as follows:

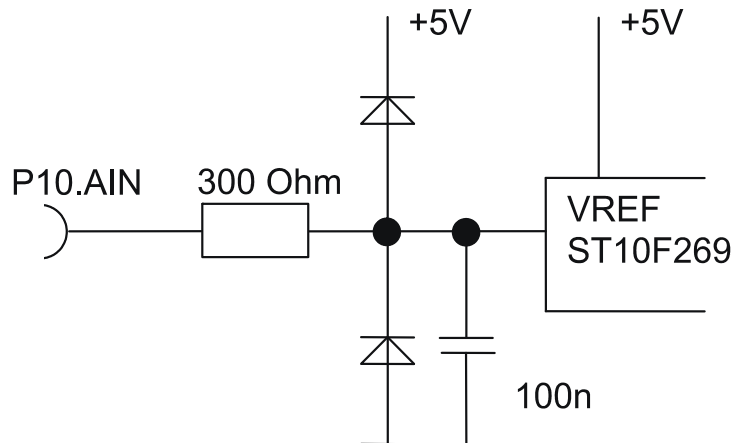

**Figure 2-5** Wiring of the analogue inputs

Following the protective circuit, the analogue port is routed directly to the ST10 processor. The reference voltage is directly the supply voltage from the backplane and thus relatively imprecise.

Thus, the analogue port can be used for simple measurement tasks. For increased accuracy demands or measurement speeds, further TSVP modules (R&S TS-PSAM, R&S TS-PIO2, R&S TS-PAM) are available.

The following function call reads the analogue voltage at a port pin:

```
ViStatus rspio3b_ReadADC (
    ViSession instrumentHandle,
    ViInt32 channel,
    ViPReal64 pVoltage);
```

### 2.6.4 SPI

The SPI interface integrated in the ST10 processor is used internally for controlling ports P0 – P7. However, it is also available at X10 and can thus be used freely – with external additional wiring.

All write accesses to ports P0 – P7 cause parallel activity on the external lines SCLK and MOSI. To select external modules and not respond to these internal accesses, these modules must be receive a Chip Select signal. This can be achieved through a P9 port bit, for example.

The internal ports P0-P7 do not respond to an external SPI access.

The SPI port is hardcoded to CPOL=0, CPHA=0 (SPI mode 0). Data are output on MOSI with the falling SCLK edge and MISO is read with the rising SCLK edge.

In idle mode, SCLK is on ,low', the MSB is sent or read in first.

Figure 2-6 shows an 8-bit SPI transfer, output of the value 0x51 on MOSI. The example signal applied to MISO is read in as 0x69.

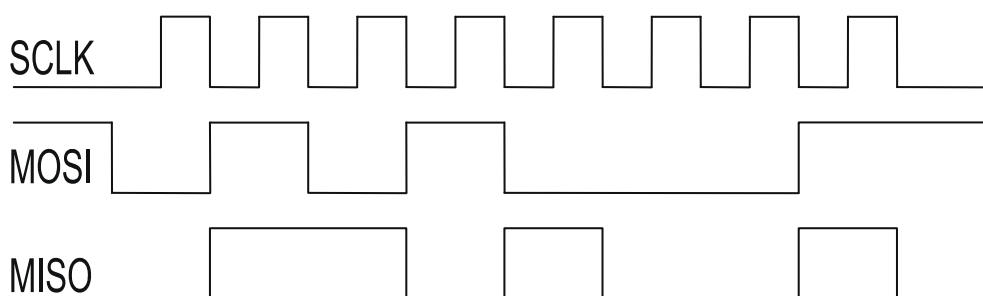

**Figure 2-6** Basic SPI cycle (8 bits)

When an R&S TS-PTRF is connected to an R&S TS-PIO3B, the generation of an external Chip Select signal for SPI accesses is handled by the R&S TS-PTRF. This functionality is described in chapter 7: Application Examples.

The following function performs an SPI transfer:

```
ViStatus rspio3b_SpiTransfer (
    ViSession instrumentHandle,
    ViChar *pTxBuffer,
    ViChar _VI_FAR pRxBuffer[],
    ViInt32 ByteCount);
```

The following function select the port, for which a ChipSelect is to be generated:

```
ViStatus rspio3b_PtrfSelectPort (
    ViSession instrumentHandle,
    ViInt32 port);
```

### 2.6.5 Voltage Sources

The R&S TS-PIO3B module provides +5 V and +12 V on X10. The voltages are fused through SMD slow-blowing fuses with a nominal value of 2 A/.



#### **CAUTION!**

**Replace the fuses with fuses of the same type. Never bridge the fuses with a wire.**

**R&S order number: 1153.3353.00**

### 2.6.6 Other Interface Signals

**CFG\_AIN, AUX1, AUX2:** Do not connect anything to these signals. They are for internal use.

**CHA\_GND:** Chassis Ground: This pin is connected to the chassis earth.

**GND:** Signal earth: These pins are connected to the digital earth. When a device under test is connected, the DUT GND must be connected to GND. To avoid ground loops, do not connect GND and CHA\_GND.

**INH:** dedicated output signal, for free use.



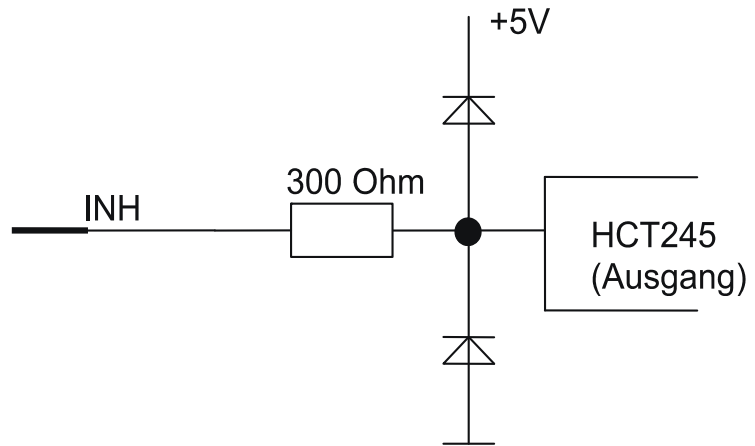

**Figure 2-7** Wiring of the INH signal

The INH signal can be checked using the following function:

```
ViStatus rspio3b_SetInhibit (
    ViSession instrumentHandle,
    ViBoolean highFlag);
```

## 2.7 Interface Description

### 2.7.1 X10 Connector on the Front

X10 connector type: 96-pin VG connector

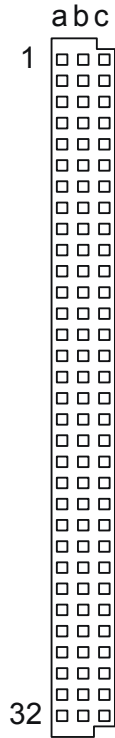

**Figure 2-8** R&S TS-PIO3B X10 connector (view: plug-in side)

X10	a	b	c
1	P0.IO0	P5.IO0	P3.IO0
2	P0.IO1	P5.IO1	P3.IO1
3	P0.IO2	P5.IO2	P3.IO2
4	P0.IO3	P5.IO3	P3.IO3
5	P0.IO4	P5.IO4	P3.IO4
6	P0.IO5	P5.IO5	P3.IO5
7	P0.IO6	P5.IO6	P3.IO6
8	P0.IO7	P5.IO7	P3.IO7

**Table 2-1** R&S TS-PIO3B, assignment of the X10 connector

<b>X10</b>	<b>a</b>	<b>b</b>	<b>c</b>
9	P1.IO0	P6.IO0	P4.IO0
10	P1.IO1	P6.IO1	P4.IO1
11	P1.IO2	P6.IO2	P4.IO2
12	P1.IO3	P6.IO3	P4.IO3
13	P1.IO4	P6.IO4	P4.IO4
14	P1.IO5	P6.IO5	P4.IO5
15	P1.IO6	P6.IO6	P4.IO6
16	P1.IO7	P6.IO7	P4.IO7
17	P2.IO0	P7.IO0	P9.TIO0
18	P2.IO1	P7.IO1	P9.TIO1
19	P2.IO2	P7.IO2	P9.TIO2
20	P2.IO3	P7.IO3	P9.TIO3
21	P2.IO4	P7.IO4	P9.TIO4
22	P2.IO5	P7.IO5	P9.TIO5
23	P2.IO6	P7.IO6	P9.TIO6
24	P2.IO7	P7.IO7	P9.TIO7
25	P10.AIN0	SCLK	CFG_AIN (*)
26	P10.AIN1	MISO	INH
27	P10.AIN2	MOSI	AUX1 (*)
28	P10.AIN3	AUX1 (*)	AUX2 (*)
29	P10.AIN4	AUX2 (*)	+5V
30	P10.AIN5	+5V	+12V
31	P10.AIN6	+12V	GND
32	P10.AIN7	GND	CHA_GND

**Table 2-1** R&S TS-PIO3B, assignment of the X10 connector

(\*) : To prevent malfunctions, the signals must not be used.

### 2.7.2 PXI Bus connector X1

X1 connector type:: CPCI socket terminal connector, 110-pin

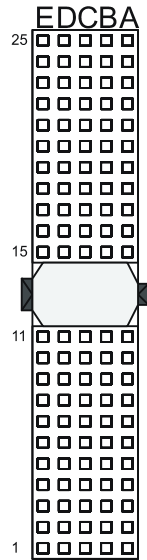

**Figure 2-9** R&S TS-PIO3B X1 connector

Pin	Z	A	B	C	D	E	F
25	GND	+5V_IN				+5V_IN	GND
24	GND		+5V_IN				GND
23	GND	+3.3V_IN					GND
22	GND		GND	+3.3V_IN			GND
21	GND	+3.3V_IN					GND
20	GND		GND				GND
19	GND	+3.3V_IN			GND		GND
18	GND		GND	+3.3V_IN			GND
17	GND	+3.3V_IN			GND		GND
16	GND		GND				GND
15	GND	+3.3V_IN					GND
14	Co- ding						Co- ding
13							
12							
11	GND				GND		GND

**Table 2-2** R&S TS-PIO3B, assignment of the X1 connector

Pin	Z	A	B	C	D	E	F
10	GND		GND	+3.3V_IN			GND
9	GND				GND		GND
8	GND		GND				GND
7	GND				GND		GND
6	GND		GND	+3.3V_IN			GND
5	GND				GND		GND
4	GND						GND
3	GND				+5V_IN		GND
2	GND						GND
1	GND	+5V_IN			+12V_IN	+5V_IN	GND

**Table 2-2** R&S TS-PIO3B, assignment of the X1 connector

### 2.7.3 PXI Bus connector X20

X20 connector type:: CPCI design AB22, socket terminal connector, 110-pin

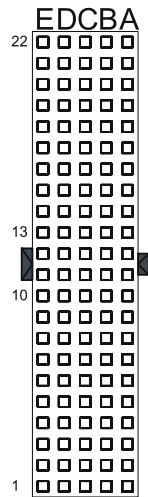

**Figure 2-10** R&S TS-PIO3B X20 connector

Pin	Z	A	B	C	D	E	F
22		GA4	GA3	GA2	GA1	GA0	
21			GA5				
20		AUX2	AUX1	+5V	GND	+5V	
19		-12V	GND	+5V	AUX2	AUX1	
18		PXI_TRIG 3	PXI_TRIG 4	PXI_TRIG5	CANEN	PXI_TRIG 6	
17		PXI_TRIG 2	GND	RRS232_RX	RRS232_T X	PXI_CLK1 0	
16		PXI_TRIG 1	PXI_TRIG 0	RRS232_RT S	GND	PXI_TRIG 7	
15			GND	RRS232_CT S	+5V		
14			RSLED[0] (RED)	RSLED[1] (YELLOW)	RSLED[2] (GREEN)		
13							

**Table 2-3** R&S TS-PIO3B, assignment of the X20 connector

Pin	Z	A	B	C	D	E	F
12	Co- ding	P7.IO0		P6.IO0		P5.IO0	Co- ding
11		P7.IO1		P6.IO1		P5.IO1	
10		P7.IO2		P6.IO2		P5.IO2	
9		P7.IO3		P6.IO3		P5.IO3	
8		P7.IO4		P6.IO4		P5.IO4	
7		P7.IO5		P6.IO5		P5.IO5	
6		P7.IO6		P6.IO6		P5.IO6	
5		P7.IO7		P6.IO7		P5.IO7	
4							
3		RSDO	GND		RINH	RSA0	
2		RSCLK	RSA2	RSA1	RSDI	+12V	
1		RCS	GND	CAN_H	CAN_L	+5V	

**Table 2-3** R&S TS-PIO3B, assignment of the X20 connector

### 2.7.4 X40 connector

X40 connector type: 3 mm connector, double-row, 14-pin

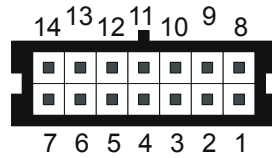

**Figure 2-11** R&S TS-PIO3B X40 connector

Pin	Assignment	Pin	Assignment
1	GND	8	GND
2	GND	9	AUX 2
3	+5 V	10	GND
4	GND	11	CAN_H
5	+12 V	12	CAN_L
6	GND	13	GND
7	AUX 1	14	GND

**Table 2-4** R&S TS-PIO3B, assignment of the X40 connector



## 3 R&S TS-PTR

### 3.1 General

The Signal Transmission Module R&S TS-PTR is a passive adapter module for routing signals through the TSVP. The module is mechanically compatible to the digital I/O module R&S TS-PIO3B.

To route the signals to the rear panel, for installation in slots A1 and A2, an R&S TS-PXB2 module and for installation in slots 3-14 a Rear Transmission Module R&S TS-PRIO4 is additionally required.

To route the signals to the front panel of the R&S CompactTSVP or R&S PowerTSVP, a Port Transmission Module R&S TS-PTRF is required.

Figure 1-1 shows various installation options.

### 3.2 Features

24 passive lines between X20 and X10
+5 V / 2 A and +12 V / 2 A fused on the front connector (X10) available

### 3.3 View

Figure 3-1 shows the R&S TS-PTR module.

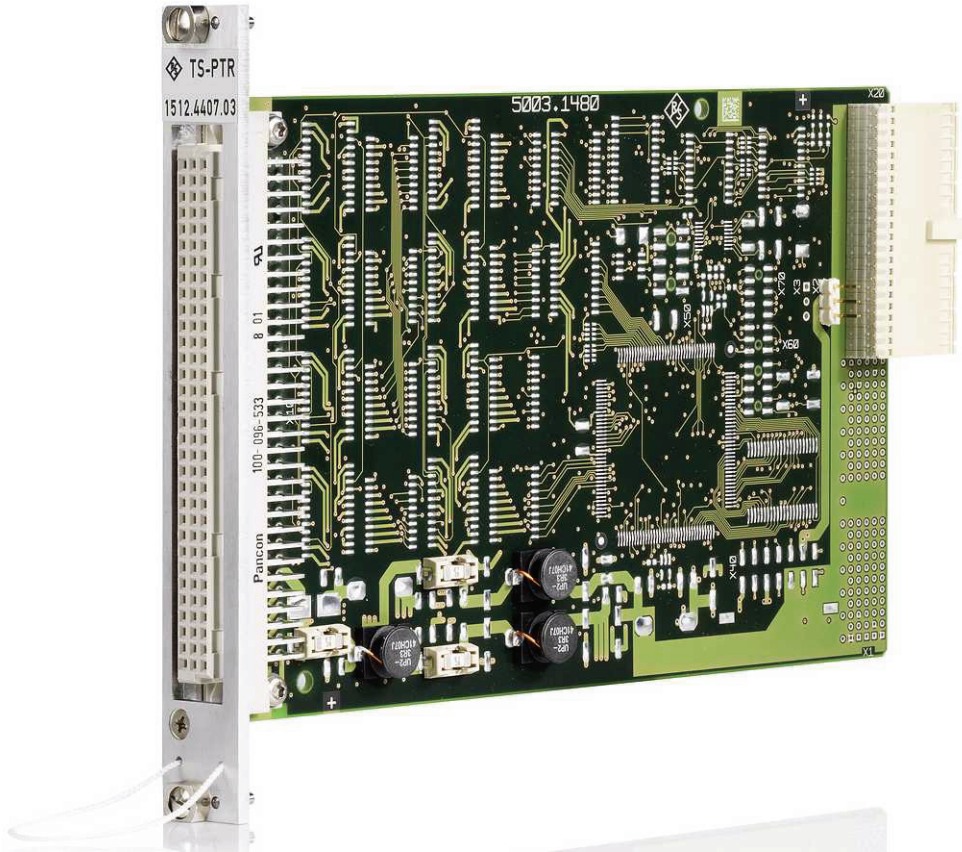
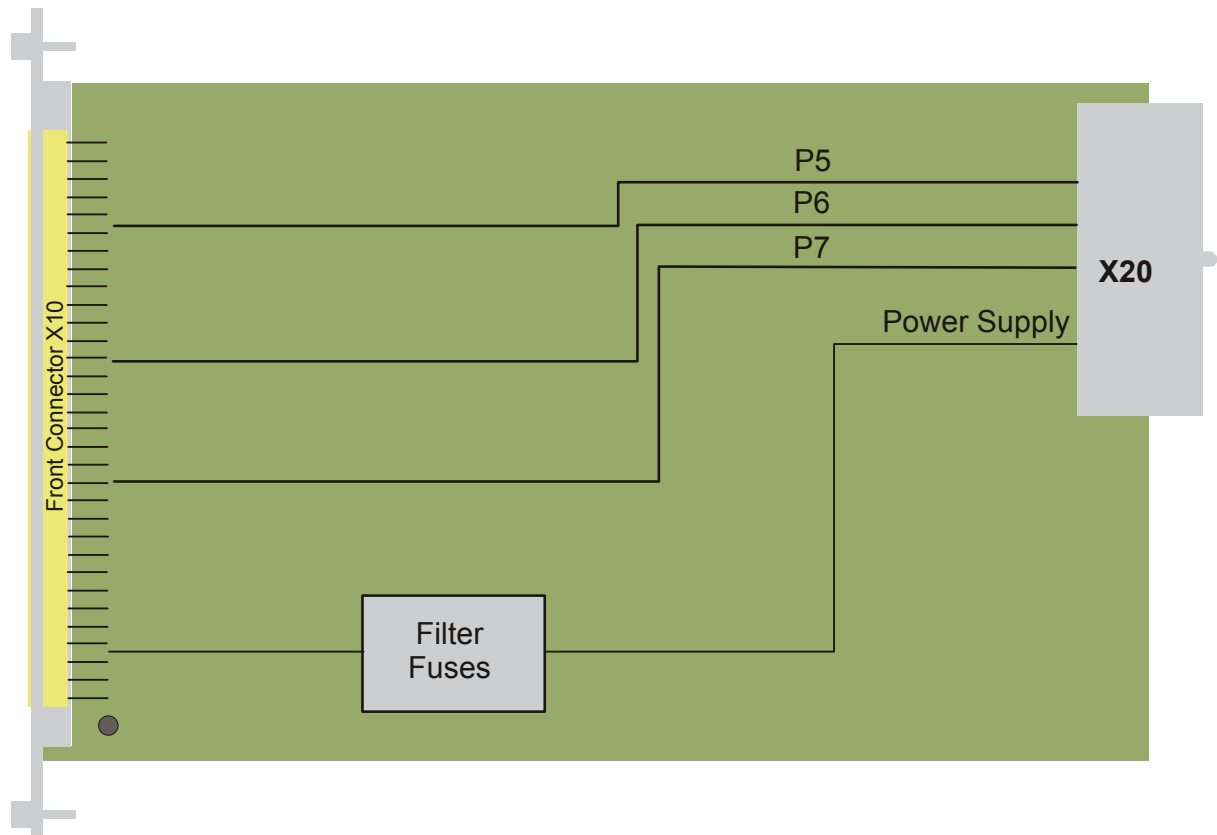

**Figure 3-1** View of the R&S TS-PTR module

### 3.4 Block Diagram and Mechanical Layout

The R&S TS-PTR module is designed as a short plug-in card (approx. 160 x 100 mm) for installation on the front of the R&S CompactTSVP or R&S PowerTSVP test platforms. The X10 connector on the front either serves for the direct connection of devices under test or for connecting the R&S TS-PTRF adapter module. The X20 connector connects the module to the CompactPCI backplane/PXI control backplane of the R&S CompactTSVP or R&S PowerTSVP.

Figure 3-2 shows the simplified function block diagram and the mechanical structure of the R&S TS-PTR module.



**Figure 3-2** Simplified diagram and mechanical structure of the R&S TS-PTR

### 3.5 Display Elements of the Module

The module does not feature indicators.

### 3.6 Functional Description

#### 3.6.1 Passive Wiring

The Signal Transmission Module R&S TS-PTR routes 24 lines passively from X20 to X10. The pin assignment is described in chapter 3.7: Interface Description.



### **3.6.2 Voltage Sources**

The R&S TS-PTR module provides +5 V and +12 V on X10. The voltages are fused through SMD slow-blowing fuses with a nominal value of 2 A .



**CAUTION!**

**Replace the fuses with fuses of the same type. Never bridge the fuses with a wire.**

**R&S order number: 1153.3353.00**

### 3.7 Interface Description

#### 3.7.1 X10 Connector on the Front

X10 connector type: 96-pin VG connector

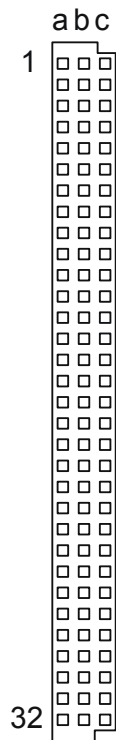

**Figure 3-3** R&S TS-PIO3B X10 connector (view: plug-in side)

X10	a	b	c
1		P5.IO0	
2		P5.IO1	
3		P5.IO2	
4		P5.IO3	
5		P5.IO4	
6		P5.IO5	
7		P5.IO6	
8		P5.IO7	
9		P6.IO0	

**Table 3-1** R&S TS-PTR, assignment of the X10 connector



<b>X10</b>	<b>a</b>	<b>b</b>	<b>c</b>
10		P6.I01	
11		P6.I02	
12		P6.I03	
13		P6.I04	
14		P6.I05	
15		P6.I06	
16		P6.I07	
17		P7.I00	
18		P7.I01	
19		P7.I02	
20		P7.I03	
21		P7.I04	
22		P7.I05	
23		P7.I06	
24		P7.I07	
25			
26			
27			
28			
29			+5V
30		+5V	+12V
31		+12V	GND
32		GND	CHA_GND

**Table 3-1** R&S TS-PTR, assignment of the X10 connector

### 3.7.2 PXI Bus connector X20

X20 connector type:: CPCI design AB22, socket terminal connector, 110-pin

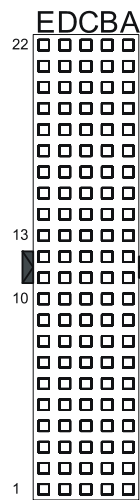

**Figure 3-4** R&S TS-PIO3B X20 connector

Pin	Z	A	B	C	D	E	F
22							
21							
20				+5V	GND	+5V	
19			GND	+5V			
18							
17			GND				
16					GND		
15			GND		+5V		
14							
13							
12	Co- ding	P7.IO0		P6.IO0		P5.IO0	Co- ding
11		P7.IO1		P6.IO1		P5.IO1	
10		P7.IO2		P6.IO2		P5.IO2	
9		P7.IO3		P6.IO3		P5.IO3	
8		P7.IO4		P6.IO4		P5.IO4	

**Table 3-2** R&S TS-PTR, assignment of the X20 connector



**R&S TS-PTR**

Pin	Z	A	B	C	D	E	F
7		P7.IO5		P6.IO5		P5.IO5	
6		P7.IO6		P6.IO6		P5.IO6	
5		P7.IO7		P6.IO7		P5.IO7	
4							
3			GND				
2						+12V	
1			GND			+5V	

**Table 3-2** R&S TS-PTR, assignment of the X20 connector



## 4 R&S TS-PRIO4

### 4.1 General

The Rear Transmission Module R&S TS-PRIO4 is a passive adapter module for the rear I/O range for routing signals from a digital I/O module R&S TS-PIO3B or a Signal Transmission Module R&S TS-PTR to the rear panel of the R&S CompactTSVP or R&S PowerTSVP.

### 4.2 Features

24 passive lines and earth between X20 and X34.

### 4.3 View

Figure 4-1 shows the R&S TS-PRIO4 module.



**Figure 4-1** View of the R&S TS-PRIO4 module

## 4.4 Block Diagram and Mechanical Layout

Figure 4-2 shows the simplified diagram and the mechanical structure of the R&S TS-PRIO4 module.

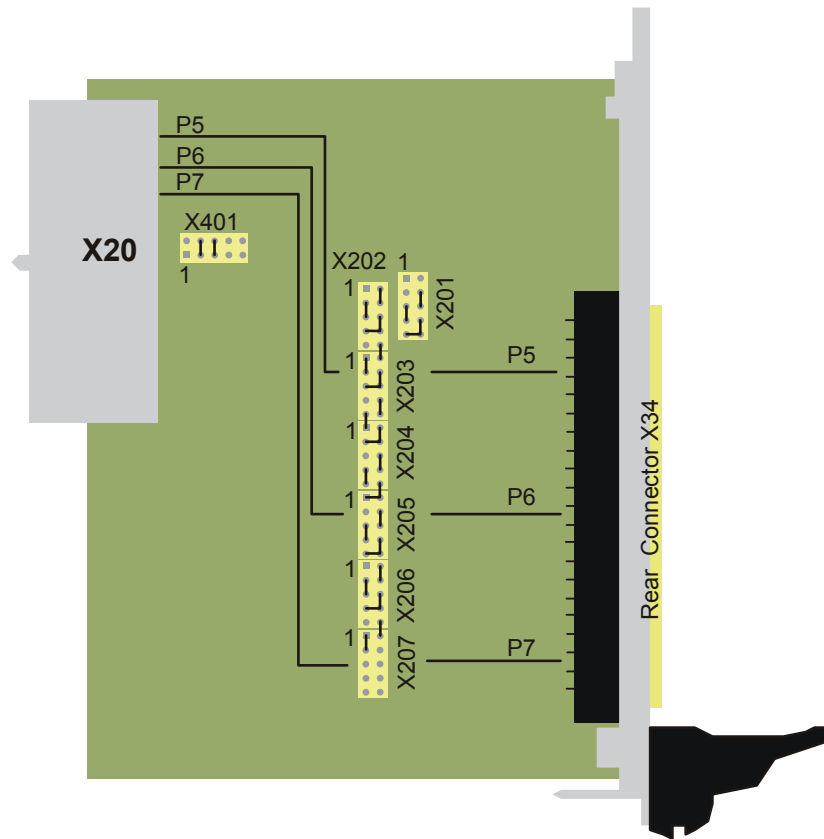

**Figure 4-2** Simplified diagram and mechanical structure of the R&S TS-PRIO4 module

## 4.5 Display Elements of the Module

The LEDs available on the R&S TS-PRIO4 module are not used in the present application.

## 4.6 Functional Description

### 4.6.1 Passive Wiring

The Rear Transmission Module R&S TS-PRIO4 routes 24 lines passively from the backplane (X20) to the rear panel (X30). The pin assignment is described in chapter 4.7: Interface Description.

## 4.7 Interface Description

### 4.7.1 PXI Bus connector X20

X20 connector type:: CPCI design AB22, socket terminal connector, 110-pin

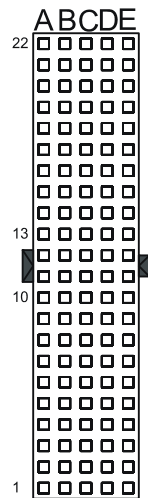

**Figure 4-3** R&S TS-PRIO4 X20 connector

Pin	Z	A	B	C	D	E	F
22							
21							
20					GND		
19			GND				
18							

**Table 4-1** R&S TS-PRIO4, assignment of the X20 connector



Pin	Z	A	B	C	D	E	F
17			GND				
16					GND		
15			GND				
14							
13							
12	Co- ding	P7.IO0		P6.IO0		P5.IO0	Co- ding
11		P7.IO1		P6.IO1		P5.IO1	
10		P7.IO2		P6.IO2		P5.IO2	
9		P7.IO3		P6.IO3		P5.IO3	
8		P7.IO4		P6.IO4		P5.IO4	
7		P7.IO5		P6.IO5		P5.IO5	
6		P7.IO6		P6.IO6		P5.IO6	
5		P7.IO7		P6.IO7		P5.IO7	
4							
3			GND				
2							
1			GND				

**Table 4-1** R&S TS-PRIO4, assignment of the X20 connector

### 4.7.2 Rear connector X34

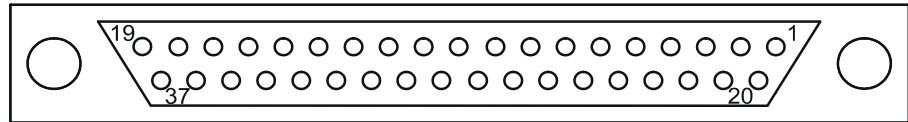

**Figure 4-4** R&S TS-PRIO4 X34 connector

Pin	Signal		Pin	Signal
1	GND		20	
2			21	
3			22	P6.IO7
4			23	P5.IO0
5	P5.IO1		24	P6.IO0
6			25	P5.IO2
7	P5.IO3		26	P6.IO1
8			27	P5.IO4
9	P5.IO5		28	P6.IO2
10			29	P5.IO6
11	P5.IO7		30	P6.IO3
12			31	P7.IO0
13	P7.IO1		32	P6.IO4
14			33	P7.IO2
15	P7.IO3		34	P6.IO5
16			35	P7.IO4
17	P7.IO5		36	P6.IO6
18			37	P7.IO6
19	P7.IO7			

**Table 4-2** R&S TS-PRIO4, assignment of the X34 connector

### 4.7.3 Jumpers

**NOTE:**

The jumpers on the module have been correctly configured ex works. They must not be changed.

The delivery status is described in the following.

X401	3-4 5-6
X201	4-6 5-7 8-10 9-10
X202	2-4 3-5 6-8 7-8 10-X203.2
X203	1-3 4-6 5-6 8-10 9-X204.1
X204	2-4 3-4 6-8 7-9 10-X205.2
X205	1-2 4-6 5-7 8-10 9-10
X206	2-4 3-5 6-8 7-8 10-X207.2
X207	1-3

## 5 R&S TS-PTRF

### 5.1 General

The Port Transmission Module R&S TS-PTRF is a ranging and distribution module and is connected on the upstream side of a digital I/O module R&S TS-PIO3B or a Signal Transmission Module R&S TS-PTR. The Port Transmission Module R&S TS-PTRF wires the 8 open drain I/O ports of the digital I/O module R&S TS-PIO3B to connectors, to which relay modules (e.g. R&S TS-PXM1) can be connected. In addition, the module generates SPI Chip Select signals for external SPI components or SPI components on the relay module.

### 5.2 Features

Wiring of the 8 open drain I/O ports of the R&S TS-PIO3B on 8 connectors (X33 – X40)
Optional wiring (via jumpers X1-X3 and X5-X9) of the 8 open drain ports of the R&S TS-PIO3B to the front panel
Optional wiring (via jumpers, X4) of the 8 analogue inputs of the R&S TS-PIO3B to the front panel
Buffering of the SPI signals and optional wiring (via jumpers X42) to the front panel
Generation of 8 SPI Chip Select signals and optional wiring (via jumper X41) to the front panel
Generation of a local 5-V supply to the front panel and to the connected relay modules

### 5.3 View

Figure 5-1 shows the R&S TS-PTRF module.

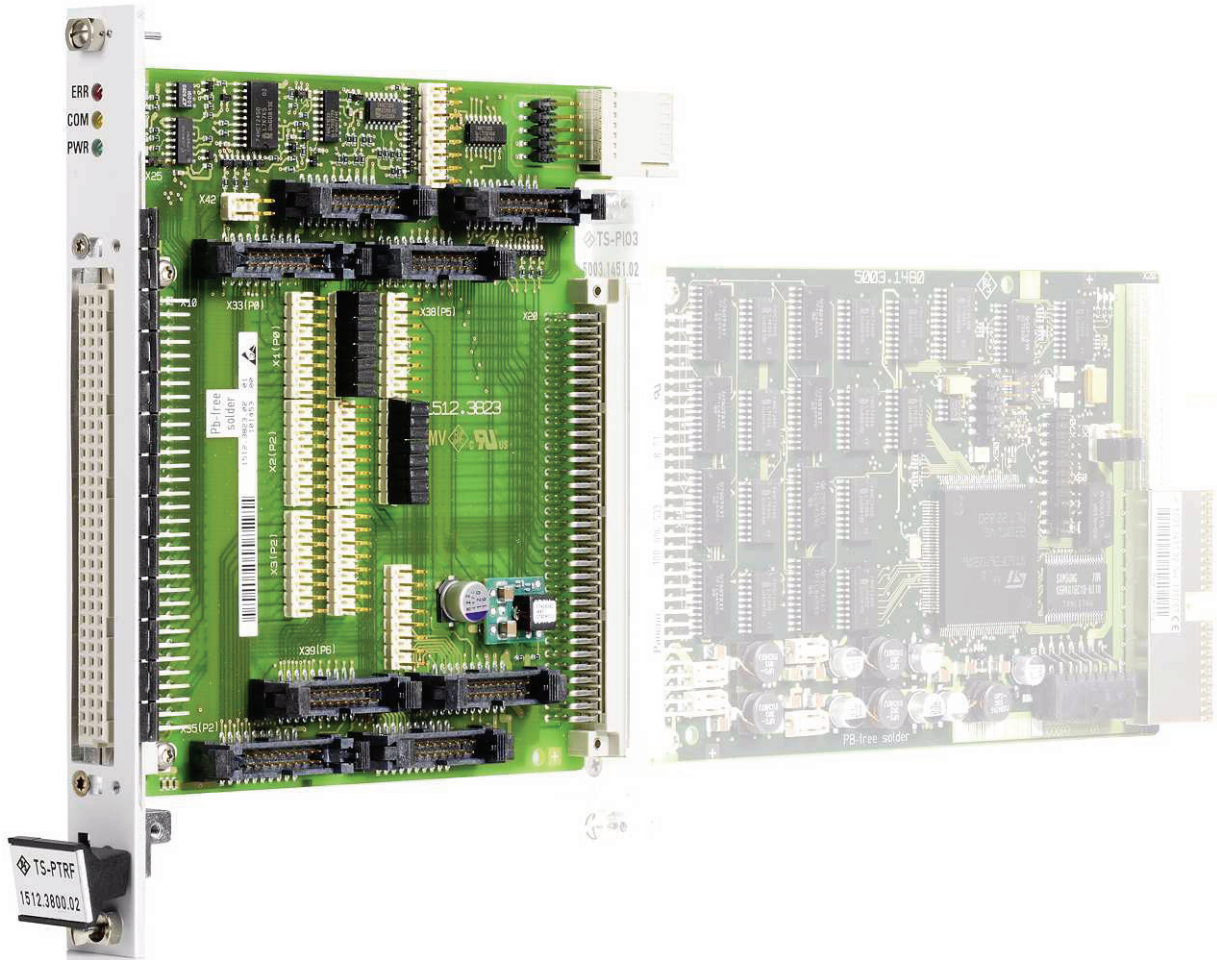
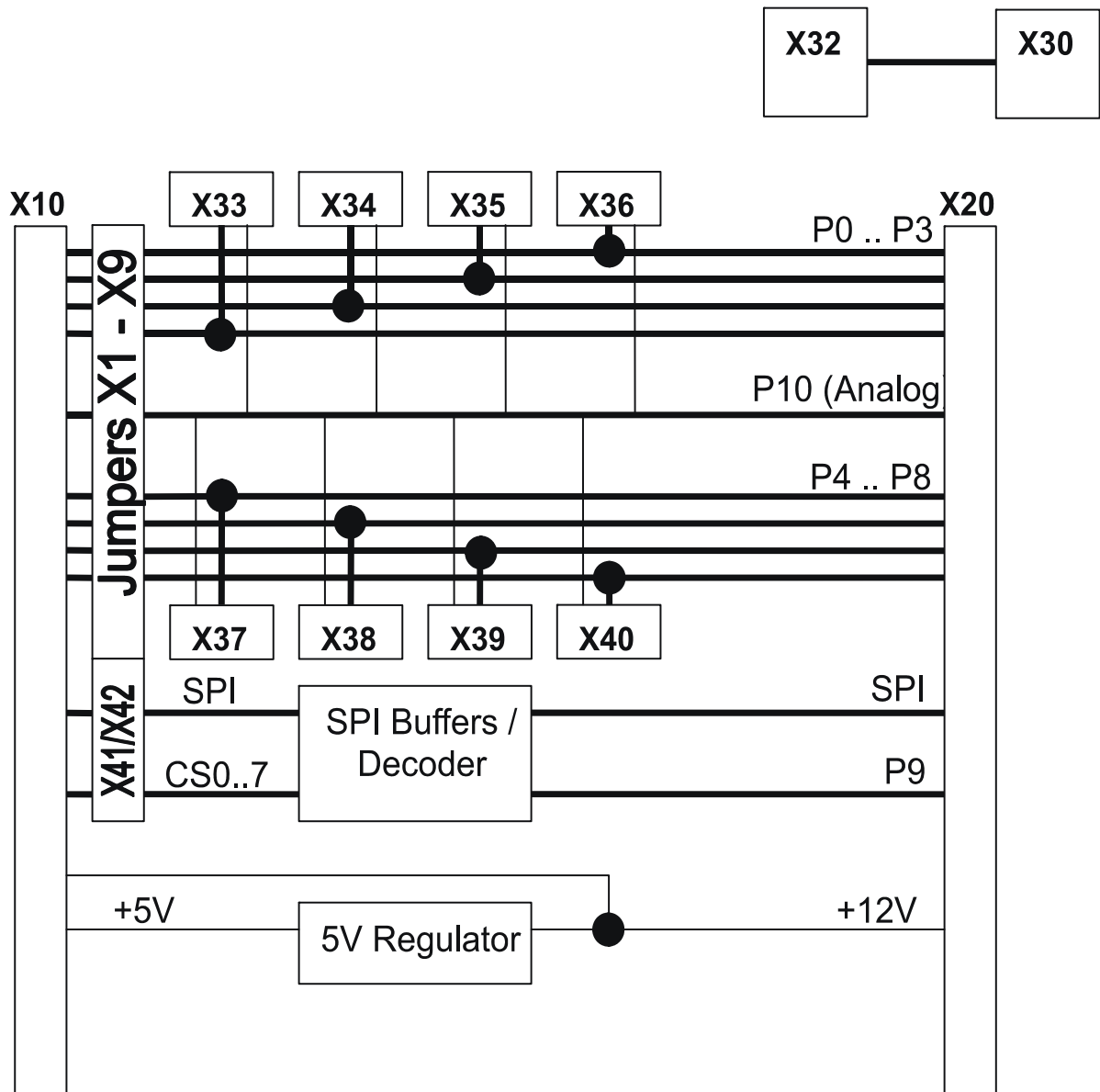

**Figure 5-1** View of the R&S TS-PTRF module (with R&S TS-PIO3B)



### 5.4 Block Diagram

Figure 5-2 shows the simplified function block diagram of the R&S TS-PTRF module.



**Figure 5-2** Block diagram of the R&S TS-PTRF

## 5.5 Mechanical Layout

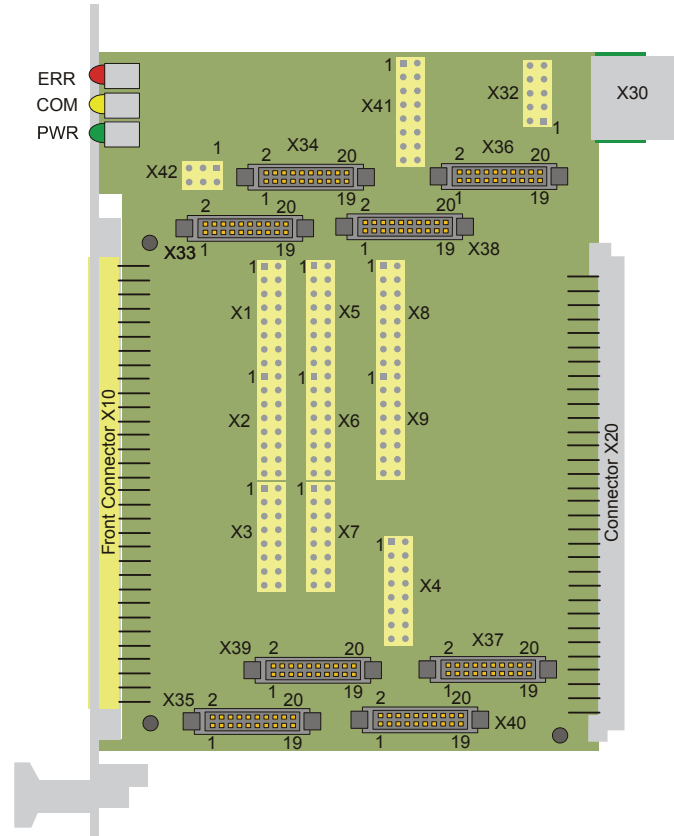

**Figure 5-3** Mechanical Layout of the &S TS-PTRF

## 5.6 Display Elements of the Module

There are three LEDs (light-emitting diodes) on the front of the Port Transmission Module R&S TS-PTRF. These LEDs indicate the actual status of the R&S TS-PIO3B connected to the R&S TS-PTRF. Description of the LEDs:

LED	Description
red	Error status. Lights up for checking purposes for approx. 3 s upon startup or when the R&S TS-PIO3B has detected an error. If the LED glows weakly, the microcontroller of the R&S TS-PIO3B is in the reset state.
yellow	Communication. Lights up for checking purposes for approx. 3 s upon startup or when the R&S TS-PIO3B has received a command from the host that performs an SPI transfer.
green	Supply voltage OK: Lights up when all the supply voltages are applied.

**Table 5-1** Indicators of the R&S TS-PTRF

If the R&S TS-PTRF is operated on the R&S TS-PTR, all the LEDs will remain off.

## 5.7 Functional Description

### 5.7.1 Wiring of the open drain I/O ports and the analogue inputs of the R&S TS-PIO3B

The Port Transmission Module R&S TS-PTRF contacts each of the open drain I/O ports (0-7) of the connected R&S TS-PIO3B to exactly one of the connectors X33 to X40. In addition, each of the open drain I/O ports of the R&S TS-PIO3B can optionally be wired to the front panel via jumpers.

The 8 analogue inputs of the R&S TS-PIO3B can optionally be wired to the front panel via jumpers. In addition, each of the analogue lines is connected to exactly one of the X33 to X40 connectors.

If a module is connected to X33 to X40, the corresponding port should not be used externally.

Figure 5-4 shows this basic wiring

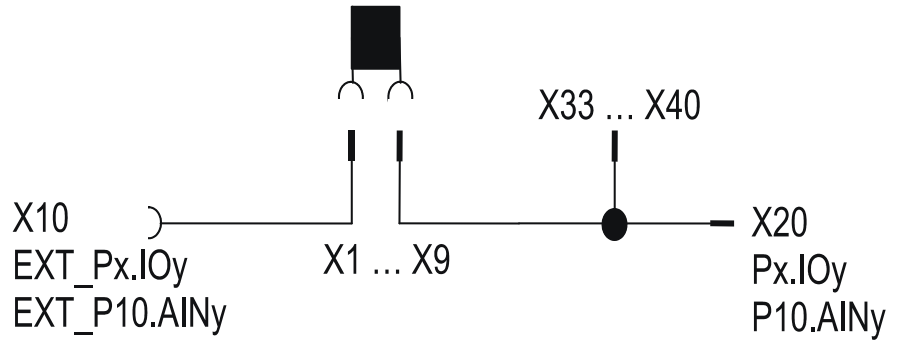

**Figure 5-4** Wiring of the R&S TS-PIO3B ports P0 – P7 and P10

The assignment according to Table 5-2 applies:

R&S TS-PIO3B Port	R&S TS-PTRF X20	R&S TS-PTRF connector	Jumpers to the front panel
P0.IOx	EXT_P0.IOx	X33	X1
P1.IOx	EXT_P1.IOx	X34	X2
P2.IOx	EXT_P2.IOx	X35	X3
P3.IOx	EXT_P3.IOx	X36	X8
P4.IOx	EXT_P4.IOx	X37	X9
P5.IOx	EXT_P5.IOx	X38	X5
P6.IOx	EXT_P6.IOx	X39	X6
P7.IOx	EXT_P7.IOx	X40	X7
P10.AINx	EXT_P10.AINx	X33-X40 (*)	X4

**Table 5-2** Wiring of the 8 bit ports of the R&S TS-PIO3B on the R&S TS-PTRF (x = 0..7)

(\*) P10.AIN0 = X33 etc. ... P10.AIN7 = X40

As can be seen in Figure 5-4, the R&S TS-PTRF features a jumper to the front panel for each bit of an open drain I/O port or of the analogue port of the R&S TS-PIO3B. If a complete port is to be wired to the front panel, 8 jumpers must be plugged.

The pin assignment according to Table 5-3 applies to each of these ports:

Bit	pins to be bridged (X33 – X40)
0	1-2
1	3-4
2	5-6
3	7-8
4	9-10
5	11-12
6	13-14
7	15-16

**Table 5-3** Connector pin assignment for ports of the R&S TS-PIO3B on the R&S TS-PTRF

### 5.7.2 Function of port P9.TIO of the R&S TS-PIO3B

If an R&S TS-PTRF is plugged onto an R&S TS-PIO3B, the R&S TS-PIO3B will recognize the R&S TS-PTRF upon booting and will use P9.TIO to control various functions on the R&S TS-PTRF. Thus, the P9.TIO can no longer be used. For this reason, P9.TIO is not available on any R&S TS-PTRF connector.

### 5.7.3 SPI

The R&S TS-PTRF contains logic components for buffering and generating the Chip Select signals for externally and internally connected SPI modules (to connectors X33 – X40). The CS signals are low active, the R&S TS-PTRF features a 10-kOhm pull-up resistor to +5 V.

The SPI signals SCLK, MOSI and MISO of the R&S TS-PIO3B are buffered and routed to connectors X33 to X40 and to the connected relay modules. In addition, the SPI signals SCLK, MOSI and MISO can be routed to the front panel (X10) via jumpers X41 and X42.

The R&S TS-PTRF generates eight SPI Chip Select signals (low active) from the R&S TS-PIO3B port P9.TIO. One CS signal each is wired to X33 to X40 and can be routed in parallel to the front panel (X10) via

a jumper.

Figure 5-5 shows a simplified diagram of the wiring:

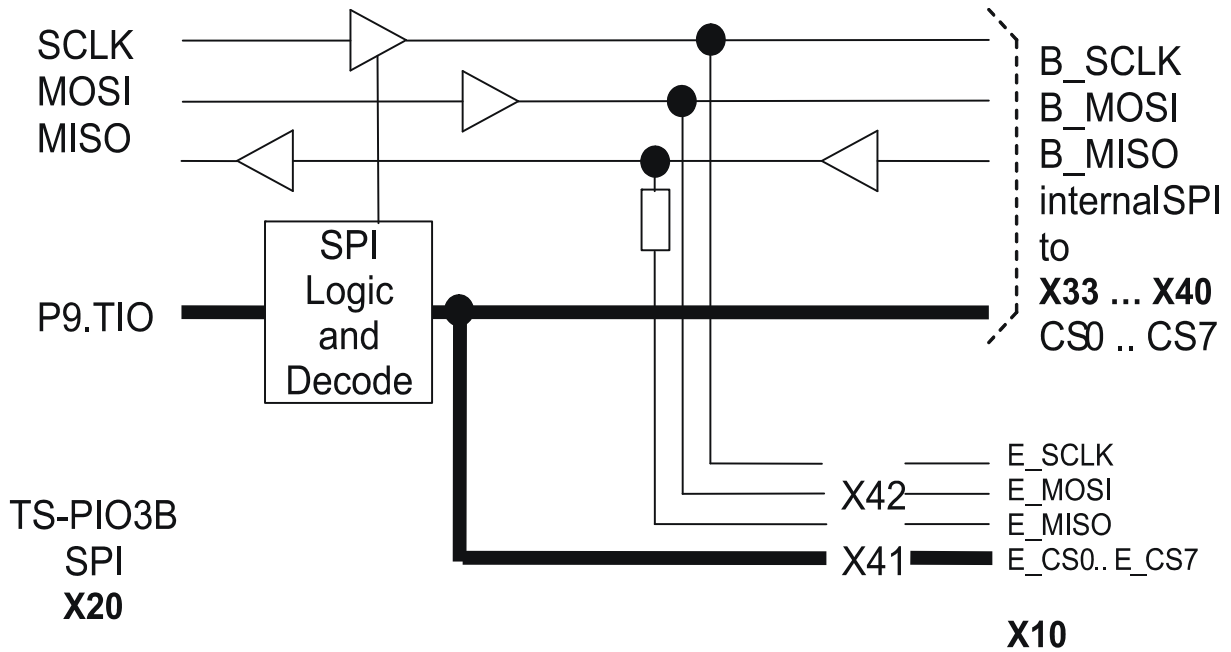

**Figure 5-5** Simplified diagram of the SPI

From this wiring and the internal logics of the R&S TS-PIO3B follows:

- To be able to connect an SPI module externally, all the X42 jumpers and one ChipSelect (one jumper on X41) must be plugged.
- If a (relay) module is connected to X33 to X40, the corresponding external CS should not be used.
- The relay drivers available locally on the R&S TS-PIO3B are connected to the same SPI bus. When writing to these relay drivers, the CS corresponding to the port and the E\_CS will be enabled (if the jumper is plugged) but E\_SCLK will not be generated.
- Each SPI access of the R&S TS-PIO3B, internally as well as externally, is signalled by the yellow LED of the R&S TS-PTRF.

#### **5.7.4 +5 V / +12 V Voltages**

The R&S TS-PTRF receives +12-V supply voltage from the R&S TS-PIO3B or the R&S TS-PTR. This supply voltage is converted to +5 V locally on the R&S TS-PTRF. These +5 V are available externally and to all the ports P0-P7 at connectors X33 to X40. (Relay) modules connected to these connectors (e.g. R&S TS-PXM1) may be supplied by these +5 V (refer to the datasheet of the module), which reduces the current available to external loads accordingly. The 5-V converter can deliver a max. output current of 2 A.

The +12 V are fused on the R&S TS-PIO3B / R&S TS-PTR by fuses. The +5 V generated locally are not fused.

#### **5.7.5 Analogue Bus Access**

The R&S TS-PTRF features a connector to the analogue bus. If the R&S TS-PTRF is used in slots 3 - 14 in the R&S CompactTSVP or 1 to 14 in the R&S PowerTSVP, connector X30 will contact the analogue bus. The 8 lines of the analogue bus are routed to connector X32.

## 5.8 Interface Description

### 5.8.1 X10 Connector on the Front

X10 connector type: 96-pin VG connector

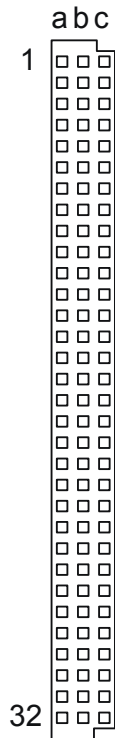

**Figure 5-6** R&S TS-PTRF X10 connector (view: plug-in side)

X10	a	b	c
1	EXT_P0.IO0	EXT_P5.IO0	EXT_P3.IO0
2	EXT_P0.IO1	EXT_P5.IO1	EXT_P3.IO1
3	EXT_P0.IO2	EXT_P5.IO2	EXT_P3.IO2
4	EXT_P0.IO3	EXT_P5.IO3	EXT_P3.IO3
5	EXT_P0.IO4	EXT_P5.IO4	EXT_P3.IO4
6	EXT_P0.IO5	EXT_P5.IO5	EXT_P3.IO5
7	EXT_P0.IO6	EXT_P5.IO6	EXT_P3.IO6
8	EXT_P0.IO7	EXT_P5.IO7	EXT_P3.IO7

**Table 5-4** R&S TS-PTRF, assignment of the X10 connector



<b>X10</b>	<b>a</b>	<b>b</b>	<b>c</b>
9	EXT_P1.IO0	EXT_P6.IO0	EXT_P4.IO0
10	EXT_P1.IO1	EXT_P6.IO1	EXT_P4.IO1
11	EXT_P1.IO2	EXT_P6.IO2	EXT_P4.IO2
12	EXT_P1.IO3	EXT_P6.IO3	EXT_P4.IO3
13	EXT_P1.IO4	EXT_P6.IO4	EXT_P4.IO4
14	EXT_P1.IO5	EXT_P6.IO5	EXT_P4.IO5
15	EXT_P1.IO6	EXT_P6.IO6	EXT_P4.IO6
16	EXT_P1.IO7	EXT_P6.IO7	EXT_P4.IO7
17	EXT_P2.IO0	EXT_P7.IO0	E_CS0
18	EXT_P2.IO1	EXT_P7.IO1	E_CS1
19	EXT_P2.IO2	EXT_P7.IO2	E_CS2
20	EXT_P2.IO3	EXT_P7.IO3	E_CS3
21	EXT_P2.IO4	EXT_P7.IO4	E_CS4
22	EXT_P2.IO5	EXT_P7.IO5	E_CS5
23	EXT_P2.IO6	EXT_P7.IO6	E_CS6
24	EXT_P2.IO7	EXT_P7.IO7	E_CS7
25	EXT_P10.AIN0	E_SCLK	
26	EXT_P10.AIN1	E_MISO	INH
27	EXT_P10.AIN2	E_MOSI	AUX1 (*)
28	EXT_P10.AIN3	AUX1 (*)	AUX2 (*)
29	EXT_P10.AIN4	AUX2 (*)	+5V
30	EXT_P10.AIN5	+5V	+12V
31	EXT_P10.AIN6	+12V	GND
32	EXT_P10.AIN7	GND	CHA_GND

**Table 5-4** R&S TS-PTRF, assignment of the X10 connector

(\*) : Signals must not be used to prevent malfunctions.

### 5.8.2 Internal X20 connector

X20 connector type: 96-pin VG connector, plug



**Figure 5-7** R&S TS-PTRF X20 connector (view: plug-in side)

X10	a	b	c
1	P0.IO0	P5.IO0	P3.IO0
2	P0.IO1	P5.IO1	P3.IO1
3	P0.IO2	P5.IO2	P3.IO2
4	P0.IO3	P5.IO3	P3.IO3
5	P0.IO4	P5.IO4	P3.IO4
6	P0.IO5	P5.IO5	P3.IO5
7	P0.IO6	P5.IO6	P3.IO6
8	P0.IO7	P5.IO7	P3.IO7
9	P1.IO0	P6.IO0	P4.IO0
10	P1.IO1	P6.IO1	P4.IO1
11	P1.IO2	P6.IO2	P4.IO2
12	P1.IO3	P6.IO3	P4.IO3

**Table 5-5** R&S TS-PTRF, assignment of the X20 connector

<b>X10</b>	<b>a</b>	<b>b</b>	<b>c</b>
13	P1.IO4	P6.IO4	P4.IO4
14	P1.IO5	P6.IO5	P4.IO5
15	P1.IO6	P6.IO6	P4.IO6
16	P1.IO7	P6.IO7	P4.IO7
17	P2.IO0	P7.IO0	P9.TIO0
18	P2.IO1	P7.IO1	P9.TIO1
19	P2.IO2	P7.IO2	P9.TIO2
20	P2.IO3	P7.IO3	P9.TIO3
21	P2.IO4	P7.IO4	P9.TIO4
22	P2.IO5	P7.IO5	P9.TIO5
23	P2.IO6	P7.IO6	P9.TIO6
24	P2.IO7	P7.IO7	P9.TIO7
25	P10.AIN0	SCLK	CFG_AIN
26	P10.AIN1	MISO	INH
27	P10.AIN2	MOSI	AUX1
28	P10.AIN3	AUX1	AUX2
29	P10.AIN4	AUX2	+5V
30	P10.AIN5	+5V	+12V
31	P10.AIN6	+12V	GND
32	P10.AIN7	GND	CHA_GND

**Table 5-5** R&S TS-PTRF, assignment of the X20 connector

### 5.8.3 Internal X33 connector

X33 connector type: 20-pin connector, double-row, 2 mm grid

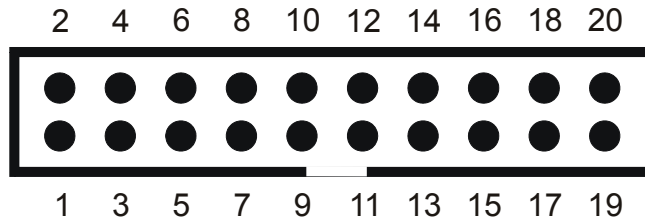

**Figure 5-8** R&S TS-PTRF X33 connector

<b>X33</b>			
1	GND	P0.IO0	2
3	P0.IO1	P0.IO2	4
5	P0.IO3	P0.IO4	6
7	P0.IO5	P0.IO6	8
9	P0.IO7	P10.AIN0	10
11	B_SCLK	B_MOSI	12
13	B_MISO	CS0	14
15	free	reserved	16
17	+5V	+5V	18
19	+12V	GND	20

**Table 5-6** R&S TS-PTRF, assignment of the X33 connector

### 5.8.4 Internal X34 connector

X34 connector type: 20-pin connector, double-row, 2 mm grid

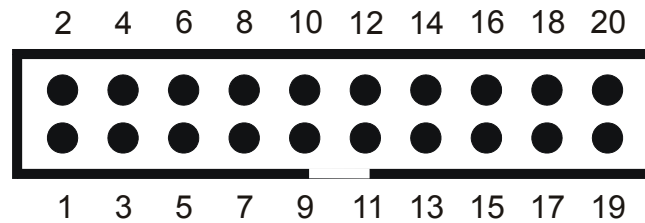

**Figure 5-9** R&S TS-PTRF X34 connector

<b>X34</b>			
1	GND	P1.IO0	2
3	P1.IO1	P1.IO2	4
5	P1.IO3	P1.IO4	6
7	P1.IO5	P1.IO6	8
9	P1.IO7	P10.AIN1	10
11	B_SCLK	B_MOSI	12
13	B_MISO	CS0	14
15	free	reserved	16
17	+5V	+5V	18
19	+12V	GND	20

**Table 5-7** R&S TS-PTRF, assignment of the X34 connector

### 5.8.5 Internal X35 connector

X35 connector type: 20-pin connector, double-row, 2 mm grid

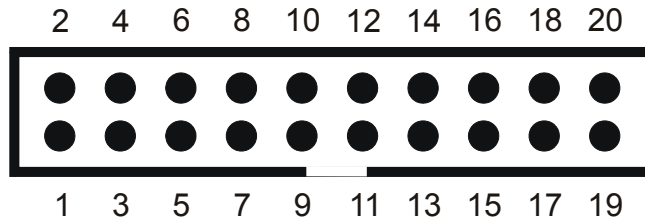

**Figure 5-10** R&S TS-PTRF X35 connector

<b>X35</b>			
1	GND	P2.IO0	2
3	P2.IO1	P2.IO2	4
5	P2.IO3	P2.IO4	6
7	P2.IO5	P2.IO6	8
9	P2.IO7	P10.AIN2	10
11	B_SCLK	B_MOSI	12
13	B_MISO	CS0	14
15	free	reserved	16
17	+5V	+5V	18
19	+12V	GND	20

**Table 5-8** R&S TS-PTRF, assignment of the X35 connector

### 5.8.6 Internal X36 connector

X36 connector type: 20-pin connector, double-row, 2 mm grid

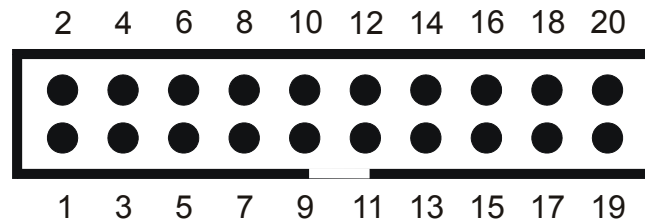

**Figure 5-11** R&S TS-PTRF X36 connector

<b>X36</b>			
1	GND	P3.IO0	2
3	P3.IO1	P3.IO2	4
5	P3.IO3	P3.IO4	6
7	P3.IO5	P3.IO6	8
9	P3.IO7	P10.AIN3	10
11	B_SCLK	B_MOSI	12
13	B_MISO	CS0	14
15	free	reserved	16
17	+5V	+5V	18
19	+12V	GND	20

**Table 5-9** R&S TS-PTRF, assignment of the X36 connector

### 5.8.7 Internal X37 connector

X37 connector type: 20-pin connector, double-row, 2 mm grid

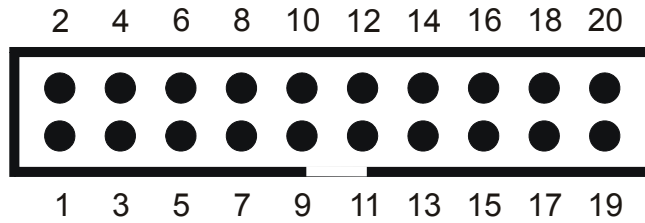

**Figure 5-12** R&S TS-PTRF X37 connector

<b>X37</b>			
1	GND	P4.IO0	2
3	P4.IO1	P4.IO2	4
5	P4.IO3	P4.IO4	6
7	P4.IO5	P4.IO6	8
9	P4.IO7	P10.AIN4	10
11	B_SCLK	B_MOSI	12
13	B_MISO	CS0	14
15	free	reserved	16
17	+5V	+5V	18
19	+12V	GND	20

**Table 5-10** R&S TS-PTRF, assignment of the X37 connector



### 5.8.8 Internal X38 connector

X38 connector type: 20-pin connector, double-row, 2 mm grid

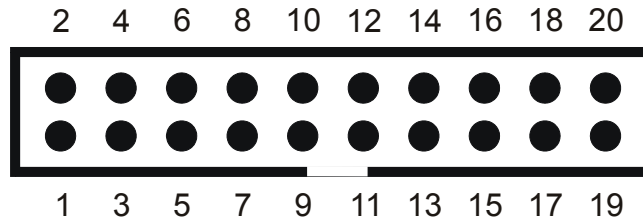

**Figure 5-13** R&S TS-PTRF X38 connector

X38			
1	GND	P5.IO0	2
3	P5.IO1	P5.IO2	4
5	P5.IO3	P5.IO4	6
7	P5.IO5	P5.IO6	8
9	P5.IO7	P10.AIN5	10
11	B_SCLK	B_MOSI	12
13	B_MISO	CS0	14
15	free	reserved	16
17	+5V	+5V	18
19	+12V	GND	20

**Table 5-11** R&S TS-PTRF, assignment of the X38 connector

**5.8.9 Internal X39 connector**

X39 connector type: 20-pin connector, double-row, 2 mm grid

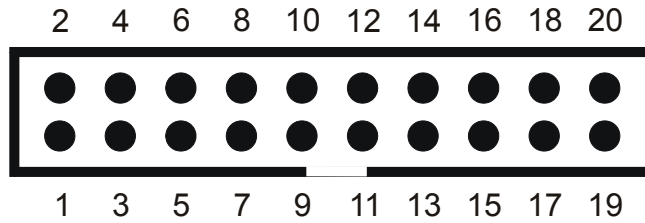

**Figure 5-14** R&S TS-PTRF X39 connector

X39			
1	GND	P6.IO0	2
3	P6.IO1	P6.IO2	4
5	P6.IO3	P6.IO4	6
7	P6.IO5	P6.IO6	8
9	P6.IO7	P10.AIN6	10
11	B_SCLK	B_MOSI	12
13	B_MISO	CS0	14
15	free	reserved	16
17	+5V	+5V	18
19	+12V	GND	20

**Table 5-12** R&S TS-PTRF, assignment of the X39 connector

### 5.8.10 Internal X40 connector

X40 connector type: 20-pin connector, double-row, 2 mm grid

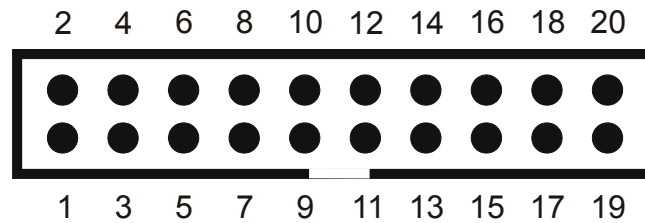

**Figure 5-15** R&S TS-PTRF X40 connector

X40			
1	GND	P7.IO0	2
3	P7.IO1	P7.IO2	4
5	P7.IO3	P7.IO4	6
7	P7.IO5	P7.IO6	8
9	P7.IO7	P10.AIN7	10
11	B_SCLK	B_MOSI	12
13	B_MISO	CS0	14
15	free	reserved	16
17	+5V	+5V	18
19	+12V	GND	20

**Table 5-13** R&S TS-PTRF, assignment of the X40 connector

### 5.8.11 Internal X1 connector

X1 connector type:: 16-pin connector, double-row, 2.54 mm grid

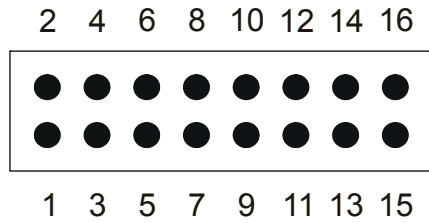

**Figure 5-16** R&S TS-PTRF X1 connector

X1			
1	EXT_P0.IO0	P0.IO0	2
3	EXT_P0.IO1	P0.IO1	4
5	EXT_P0.IO2	P0.IO2	6
7	EXT_P0.IO3	P0.IO3	8
9	EXT_P0.IO4	P0.IO4	10
11	EXT_P0.IO5	P0.IO5	12
13	EXT_P0.IO6	P0.IO6	14
15	EXT_P0.IO7	P0.IO7	16

**Table 5-14** R&S TS-PTRF, assignment of the X1 connector

### 5.8.12 Internal X2 connector

X2 connector type: 16-pin connector, double-row, 2.54 mm grid

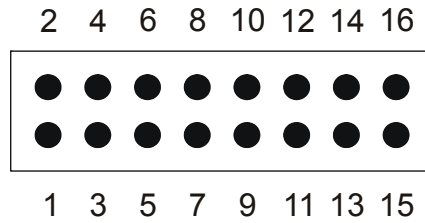

**Figure 5-17** R&S TS-PTRF X2 connector

X2			
1	EXT_P1.IO0	P1.IO0	2
3	EXT_P1.IO1	P1.IO1	4
5	EXT_P1.IO2	P1.IO2	6
7	EXT_P1.IO3	P1.IO3	8
9	EXT_P1.IO4	P1.IO4	10
11	EXT_P1.IO5	P1.IO5	12
13	EXT_P1.IO6	P1.IO6	14
15	EXT_P1.IO7	P1.IO7	16

**Table 5-15** R&S TS-PTRF, assignment of the X2 connector

### 5.8.13 Internal X3 connector

X3 connector type: 16-pin connector, double-row, 2.54 mm grid

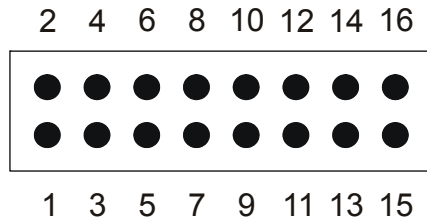

**Figure 5-18** R&S TS-PTRF X3 connector

X3			
1	EXT_P2.IO0	P2.IO0	2
3	EXT_P2.IO1	P2.IO1	4
5	EXT_P2.IO2	P2.IO2	6
7	EXT_P2.IO3	P2.IO3	8
9	EXT_P2.IO4	P2.IO4	10
11	EXT_P2.IO5	P2.IO5	12
13	EXT_P2.IO6	P2.IO6	14
15	EXT_P2.IO7	P2.IO7	16

**Table 5-16** R&S TS-PTRF, assignment of the X3 connector

### 5.8.14 Internal X4 connector

X4 connector type: 16-pin connector, double-row, 2.54 mm grid

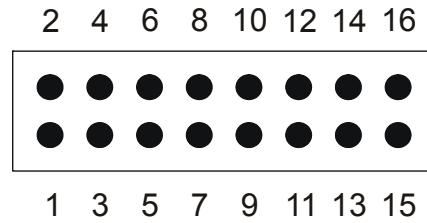

**Figure 5-19** R&S TS-PTRF X4 connector

<b>X4</b>			
1	EXT_P10. AIN 0	P10. AIN 0	2
3	EXT_P10. AIN 1	P10. AIN 1	4
5	EXT_P10. AIN 2	P10. AIN 2	6
7	EXT_P10. AIN 3	P10. AIN 3	8
9	EXT_P10. AIN 4	P10. AIN 4	10
11	EXT_P10. AIN 5	P10. AIN 5	12
13	EXT_P10. AIN 6	P10. AIN 6	14
15	EXT_P10. AIN 7	P10. AIN 7	16

**Table 5-17** R&S TS-PTRF, assignment of the X4 connector

### 5.8.15 Internal X5 connector

X5 connector type: 16-pin connector, double-row, 2.54 mm grid

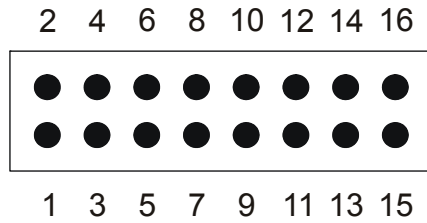

**Figure 5-20** R&S TS-PTRF X5 connector

X5			
1	EXT_P5.IO0	P5.IO0	2
3	EXT_P5.IO1	P5.IO1	4
5	EXT_P5.IO2	P5.IO2	6
7	EXT_P5.IO3	P5.IO3	8
9	EXT_P5.IO4	P5.IO4	10
11	EXT_P5.IO5	P5.IO5	12
13	EXT_P5.IO6	P5.IO6	14
15	EXT_P5.IO7	P5.IO7	16

**Table 5-18** R&S TS-PTRF, assignment of the X5 connector



### 5.8.16 Internal X6 connector

X6 connector type: 16-pin connector, double-row, 2.54 mm grid

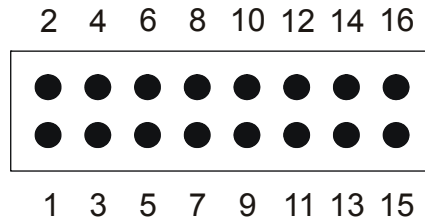

**Figure 5-21** R&S TS-PTRF X6 connector

X6			
1	EXT_P6.IO0	P6.IO0	2
3	EXT_P6.IO1	P6.IO1	4
5	EXT_P6.IO2	P6.IO2	6
7	EXT_P6.IO3	P6.IO3	8
9	EXT_P6.IO4	P6.IO4	10
11	EXT_P6.IO5	P6.IO5	12
13	EXT_P6.IO6	P6.IO6	14
15	EXT_P6.IO7	P6.IO7	16

**Table 5-19** R&S TS-PTRF, assignment of the X6 connector

### 5.8.17 Internal X7 connector

X7 connector type: 16-pin connector, double-row, 2.54 mm grid

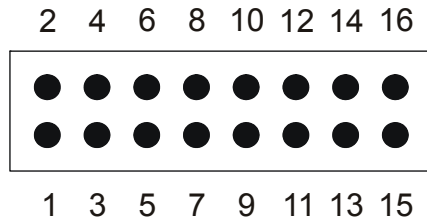

**Figure 5-22** R&S TS-PTRF X7 connector

X7			
1	EXT_P7.IO0	P7.IO0	2
3	EXT_P7.IO1	P7.IO1	4
5	EXT_P7.IO2	P7.IO2	6
7	EXT_P7.IO3	P7.IO3	8
9	EXT_P7.IO4	P7.IO4	10
11	EXT_P7.IO5	P7.IO5	12
13	EXT_P7.IO6	P7.IO6	14
15	EXT_P7.IO7	P7.IO7	16

**Table 5-20** R&S TS-PTRF, assignment of the X7 connector

### 5.8.18 Internal X8 connector

X8 connector type: 16-pin connector, double-row, 2.54 mm grid

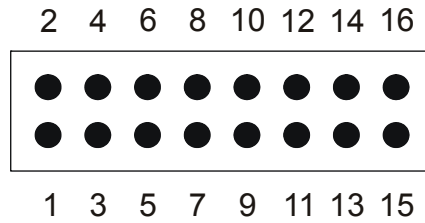

**Figure 5-23** R&S TS-PTRF X8 connector

<b>X8</b>			
1	EXT_P3.IO0	P3.IO0	2
3	EXT_P3.IO1	P3.IO1	4
5	EXT_P3.IO2	P3.IO2	6
7	EXT_P3.IO3	P3.IO3	8
9	EXT_P3.IO4	P3.IO4	10
11	EXT_P3.IO5	P3.IO5	12
13	EXT_P3.IO6	P3.IO6	14
15	EXT_P3.IO7	P3.IO7	16

**Table 5-21** R&S TS-PTRF, assignment of the X8 connector

### 5.8.19 Internal X9 connector

X9 connector type: 16-pin connector, double-row, 2.54 mm grid

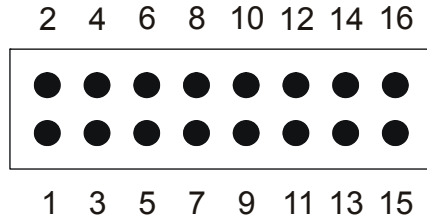

**Figure 5-24** R&S TS-PTRF X9 connector

X9			
1	EXT_P4.IO0	P4.IO0	2
3	EXT_P4.IO1	P4.IO1	4
5	EXT_P4.IO2	P4.IO2	6
7	EXT_P4.IO3	P4.IO3	8
9	EXT_P4.IO4	P4.IO4	10
11	EXT_P4.IO5	P4.IO5	12
13	EXT_P4.IO6	P4.IO6	14
15	EXT_P4.IO7	P4.IO7	16

**Table 5-22** R&S TS-PTRF, assignment of the X9 connector

### 5.8.20 Internal X41 connector

X41 connector type: 16-pin connector, double-row, 2.54 mm grid

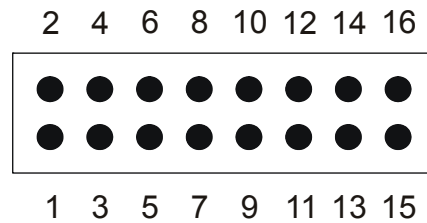

**Figure 5-25** R&S TS-PTRF X41 connector

X41			
1	E_CS0	CS0	2
3	E_CS1	CS1	4
5	E_CS2	CS2	6
7	E_CS3	CS3	8
9	E_CS4	CS4	10
11	E_CS5	CS5	12
13	E_CS6	CS6	14
15	E_CS7	CS7	16

**Table 5-23** R&S TS-PTRF, assignment of the X41 connector

### 5.8.21 Internal X42 connector

X42 connector type: 6-pin connector, double-row, 2.54 mm grid

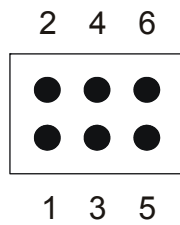

**Figure 5-26** R&S TS-PTRF X42 connector

X42			
1	B_SCLK	E_SCLK	2
3	B_MOSI	E_MOSI	4
5	B_MISO	E_MISO	6

**Table 5-24** R&S TS-PTRF, assignment of the X42 connector

### 5.8.22 Internal X32 connector

X32 connector type: 10-pin connector, double-row, 2.54 mm grid

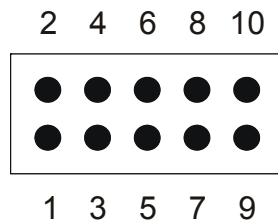

**Figure 5-27** R&S TS-PTRF X32 connector

X32			
1	AB_D1	AB_B2	2
3	AB_A1	AB_A2	4
5	AB_B1	AB_D2	6
7	AB_C2	AB_C1	8
9	free	free	10

**Table 5-25** R&S TS-PTRF, assignment of the X42 connector

### 5.8.23 Internal X30 connector

X30 connector type: Special connector 2 mm grid

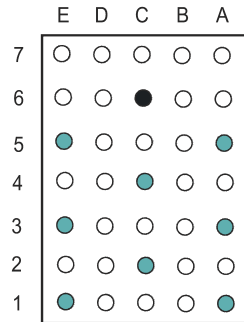

**Figure 5-28** R&S TS-PTRF X30 connector (view: plug-in side)

X30	E	D	C	B	A
7					
6			GND		
5	AB_C1				AB_A1
4			AB_B1		
3	AB_C2				AB_B2
2			AB_A2		
1	AB_D2				AB_D1

**Table 5-26** R&S TS-PTRF, assignment of the X30 connector



## 6 R&S TS-PXM1

### 6.1 General

The Switching Extension Module R&S TS-PXM1 is a relay module with a total of 32 switches arranged in 8 groups of 4 switches each. Control is implemented via a Port Transmission Module R&S TS-PTRF and a Digital I/O Module R&S TS-PIO3B. All the switching contacts are available on the X10 front connector, the common contacts of the switches are additionally available on connectors.

### 6.2 Features

32 switches, arranged in 8 groups of 4 switches each (8 x 4PDT)
Contact load capacity 2 A / 30 V DC
Control via R&S TS-PIO3B and R&S TS-PTRF
Automatic detection via EEPROM
LEDs for status display

### 6.3 View

Figure 6-1 shows the R&S TS-PXM1 module.



**Figure 6-1** View of the R&S TS-PXM1 module

### 6.4 Block Diagram

Figure 6-2 shows the function block diagram of the Switching Extension Module R&S TS-PXM1.

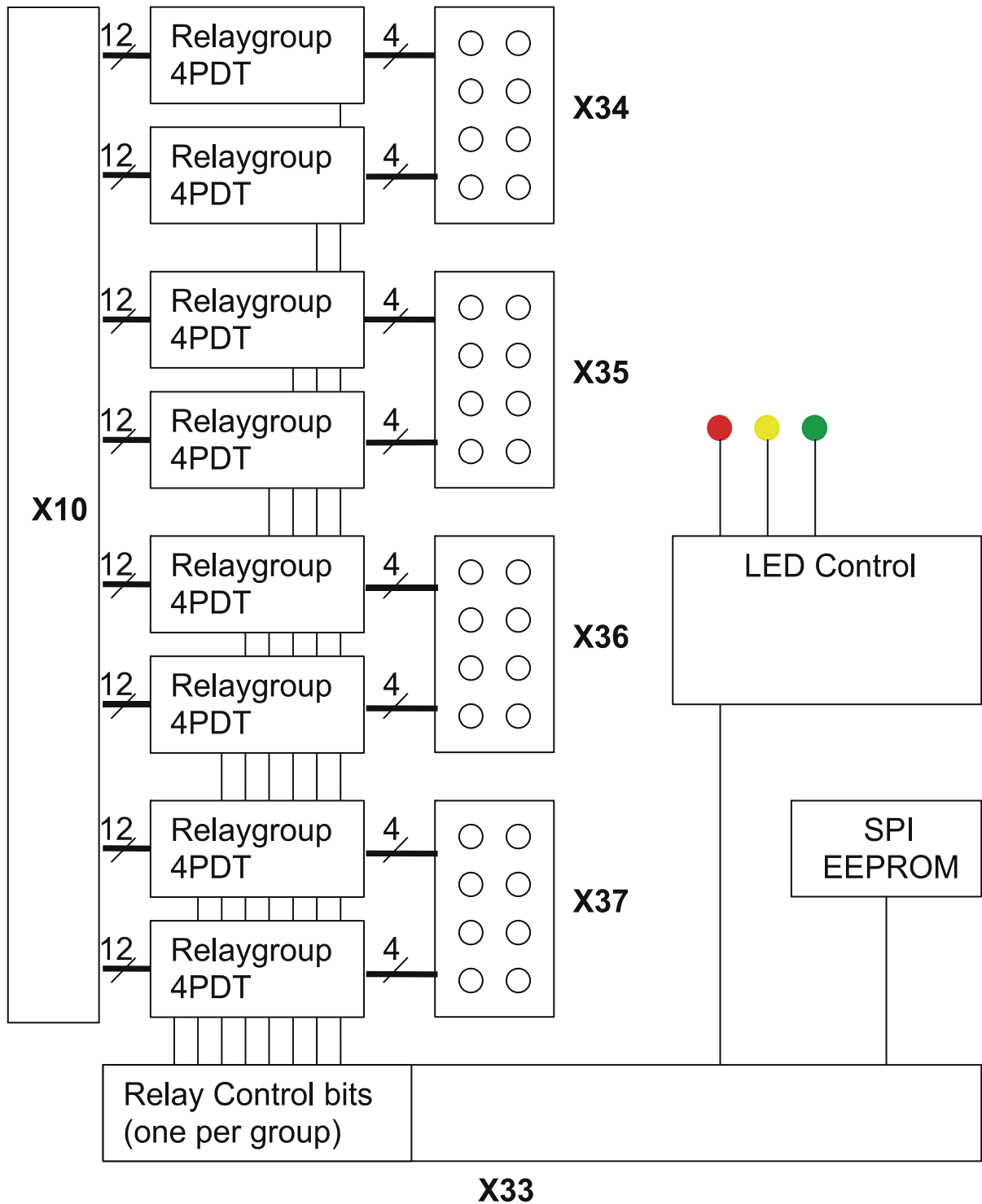

2nd Issue 09.11

**Figure 6-2** Function block diagram of the R&S TS-PXM1

Figure 6-3 shows a relay module in detail.

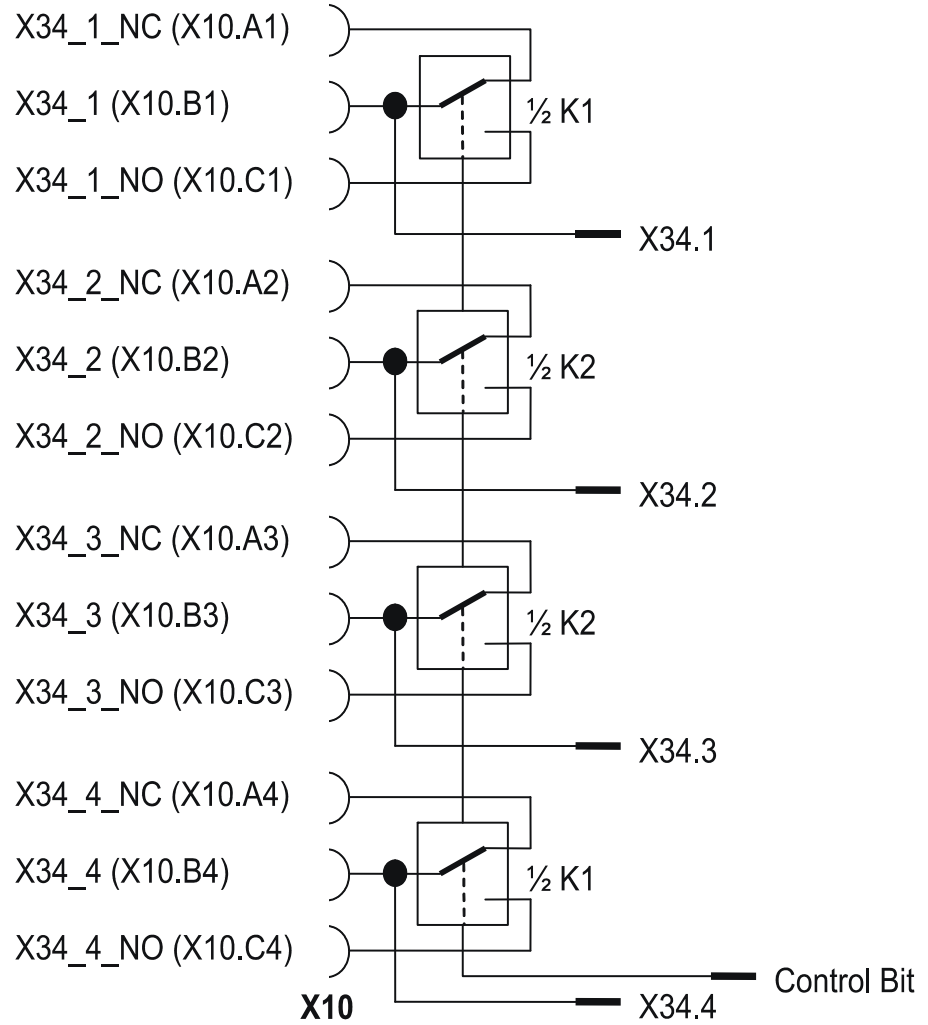

**Figure 6-3** R&S TS-PXM1 detailed example : Relay module X34.1-X34.4

### 6.5 Mechanical Layout

The following figure shows the mechanical structure of the R&S TS-PXM1.

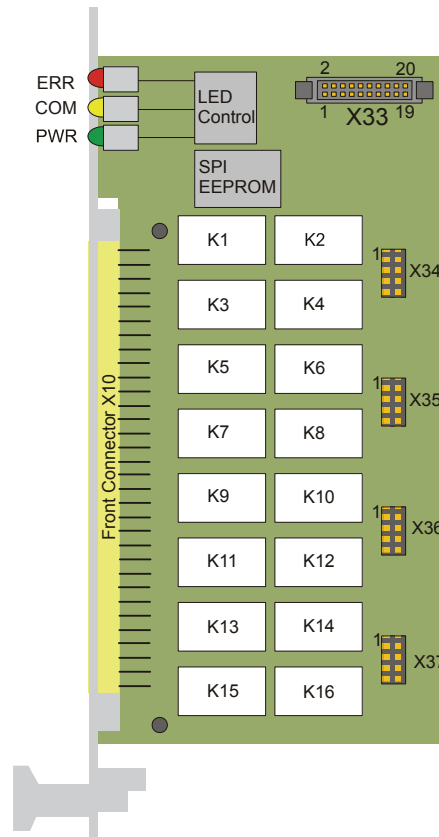

**Figure 6-4** Mechanical Layout of the R&S TS-PXM1

## 6.6 Display Elements of the Module

There are three LEDs (light-emitting diodes) on the front of the R&S TS-PXM1 module. These LEDs indicate the topical status of the module. Description of the LEDs:

LED	Description
red	Without function: Lights up for approx. 1 second upon switch-on (for reasons of compatibility to other modules)
yellow	Communication: Lights up briefly when a relay is switched or upon access to the EEPROM.
green	Supply voltage OK: Lights up when all the supply voltages are applied.

**Table 6-1** Indicators on the R&S TS-PXM1 module

## 6.7 Functional Description

### 6.7.1 Relay Wiring

The R&S TS-PXM1 module comprises 16 relays with two switches each. Two relays are always served by one control bit, which results in one 4-pin switch per bit (4PDT).

Each relay contact is routed to the front panel X10, the common connection of the switches is also routed to the internal connector. The wiring is listed in Table 6-2 and Table 6-3 (also refer to Figure 6-3).

At the VG connector the wiring is always as follows:

Row	A	B	C
n(1-32)	X(34-37)_(1-8)_NC	X(34-37)_(1-8)	X(34-37)_(1-8)_NO

**Table 6-2** Wiring of the VG connector

- \_NC: normally closed: normally closed state.
- \_NO: normally open: normally open state.
- Control bit = 1: Relay is in normal state, the switch is connected to \_NC

Control bit = 0: Relay is energized, the switch is connected to \_NO

**Table 6-3** Relay wiring

Control bit	Relay	Connector	VG96 row
0	K1 and K2	X34.1, X34.2, X34.3, X34.4	1,2,3,4
1	K3 and K4	X34.5, X34.6, X34.7, X34.8	5,6,7,8
2	K5 and K6	X35.1, X35.2, X35.3, X35.4	9,10,11,12
3	K7 and K8	X35.5, X35.6, X35.7, X35.8	13,14,15,16
4	K9 and K10	X36.1, X36.2, X36.3, X36.4	17,18,19,20
5	K11 and K12	X36.5, X36.6, X36.7, X36.8	21,22,23,24
6	K13 and K14	X37.1, X37.2, X37.3, X37.4	25,26,27,28
7	K15 and K16	X37.5, X37.6, X37.7, X37.8	29,30,31,32

### 6.7.2 EEPROM

The EEPROM available on module R&S TS-PXM1 can be read out via the SPI bus, e.g. by the R&S TS-PIO3B. The EEPROM contains identification data (identification number, change status, serial number etc.).

## 6.8 Interface Description

### 6.8.1 X10 Connector on the Front

X10 connector type: 96-pin VG connector

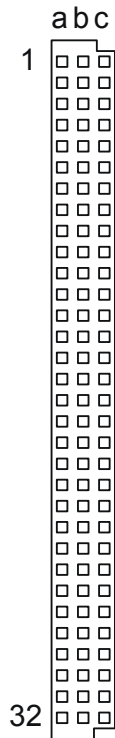

**Figure 6-5** R&S TS-PXM1 X10 connector (view from outside)

<b>X10</b>	<b>a</b>	<b>b</b>	<b>c</b>
1	X34_1_NC	X34_1	X34_1_NO
2	X34_2_NC	X34_2	X34_2_NO
3	X34_3_NC	X34_3	X34_3_NO
4	X34_4_NC	X34_4	X34_4_NO
5	X34_5_NC	X34_5	X34_5_NO
6	X34_6_NC	X34_6	X34_6_NO
7	X34_7_NC	X34_7	X34_7_NO
8	X34_8_NC	X34_8	X34_8_NO

**Table 6-4** R&S TS-PXM1, assignment of the X10 connector



<b>X10</b>	<b>a</b>	<b>b</b>	<b>c</b>
9	X35_1_NC	X35_1	X35_1_NO
10	X35_2_NC	X35_2	X35_2_NO
11	X35_3_NC	X35_3	X35_3_NO
12	X35_4_NC	X35_4	X35_4_NO
13	X35_5_NC	X35_5	X35_5_NO
14	X35_6_NC	X35_6	X35_6_NO
15	X35_7_NC	X35_7	X35_7_NO
16	X35_8_NC	X35_8	X35_8_NO
17	X36_1_NC	X36_1	X36_1_NO
18	X36_2_NC	X36_2	X36_2_NO
19	X36_3_NC	X36_3	X36_3_NO
20	X36_4_NC	X36_4	X36_4_NO
21	X36_5_NC	X36_5	X36_5_NO
22	X36_6_NC	X36_6	X36_6_NO
23	X36_7_NC	X36_7	X36_7_NO
24	X36_8_NC	X36_8	X36_8_NO
25	X37_1_NC	X37_1	X37_1_NO
26	X37_2_NC	X37_2	X37_2_NO
27	X37_3_NC	X37_3	X37_3_NO
28	X37_4_NC	X37_4	X37_4_NO
29	X37_5_NC	X37_5	X37_5_NO
30	X37_6_NC	X37_6	X37_6_NO
31	X37_7_NC	X37_7	X37_7_NO
32	X37_8_NC	X37_8	X37_8_NO

**Table 6-4** R&S TS-PXM1, assignment of the X10 connector

**6.8.2 Control: connector X33**

X33 connector type: 20-pin connector, double-row, 2 mm grid

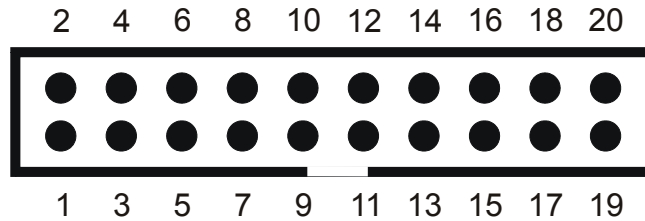

**Figure 6-6** R&S TS-PXM1 X33 connector

X33			
1	GND	bit0 (K1/K2)	2
3	bit1 (K3/K4)	bit2 (K5/K6)	4
5	bit3 (K7/K8)	bit4 (K9/K10)	6
7	bit5 (K11/K12)	bit6 (K13/K14)	8
9	bit7 (K15/K16)	free	10
11	SCLK	MOSI	12
13	MISO	CS	14
15	free	free	16
17	+5V	+5V	18
19	+12V	GND	20

**Table 6-5** R&S TS-PXM1, assignment of the X33 connector

### 6.8.3 Connectors X34 to X37

X34-X37 connector type: 8-pin connector, double-row, 2.54 mm grid

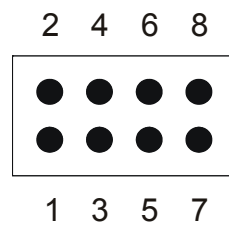

**Figure 6-7** R&S TS-PXM1 connectors X34 to X37

The signal names are identical to those of the pins.

Example: X34.Pin1 = signal name X34\_1.

The pins are wired to the VG connector (X10) column „B“ (refer to Table 6-4).



**ROHDE & SCHWARZ**

**R&S TS-PXM1**

## 7 Application Examples

### 7.1 Control of Relays / Pneumatic Valves / Vacuum Valves

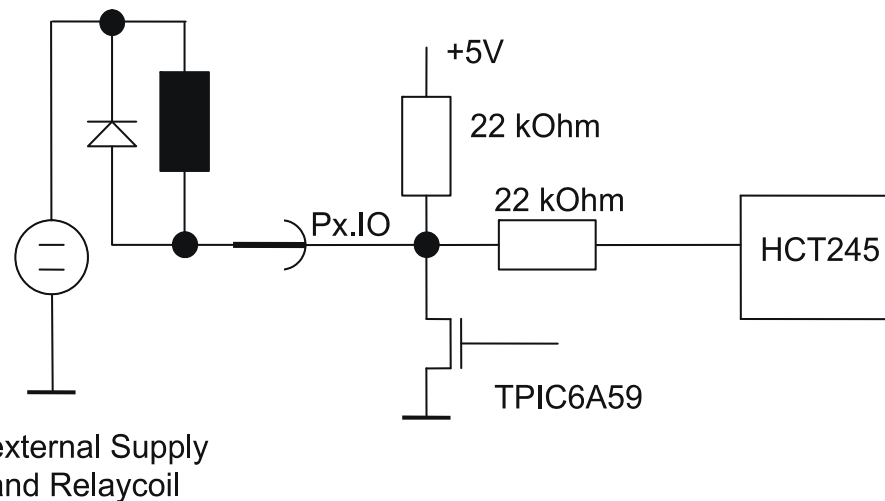

**Figure 7-1** Controlling inductive loads with R&S TS-PIO3B (example)

This example shows the control of a relay or inductive valve. The driver stage of an R&S TS-PIO3B and a coil with freewheeling diode are shown.

The externally applied voltage may be up to 30 V.

**Caution!** Due to the ,open drain' design, with external voltages of > 5 V with the port bit = ,high' (switched-off state), a current will flow from the external source through the external load and through the 22 kOhm resistors into the local 5 V supply. With 24 V, this current is approx. 1 mA (depending on the external load).

Also take into consideration that with external voltages of < 5 V with the port bit = ,high' a current will flow from the R&S TS-PIO3B into the external circuit.

## 7.2 Adapter Identification

The ports of the R&S TS-PIO3B may be used, e.g. to detect an externally connected test adapter. Two different options are shown in this context.

To be flush with the front panel of the R&S CompactTSVP or R&S PowerTSVP, an R&S TS-PTRF is required for the adapter identification. The jumpers in the PTRF must be configured accordingly (refer to chapter 5).

### 7.2.1 Parallel Adapter Identification via Ports

The parallel adapter identification is especially easy to implement but requires one or two complete 8 bit I/O ports.

To be able to identify an adapter uniquely, it is only necessary to connect wires in the adapter with GND. Port bits that have not been wired are read as „high“ by the internal pull-up resistors. The ports will then be read in via the following function, thus implementing the adapter identification.

```
ViStatus rspio3b_ReadPort (
    ViSession instrumentHandle,
    ViInt32 port,
    ViPUInt8 pattern);
```

If two ports are used, more than 65000 combinations can be set. This is sufficient to code an adapter identification and an adapter version.

### 7.2.2 Serial Adapter Identification via SPI-EEPROM

The serial adapter identification uses an SPI-EEPROM in the adapter and can be set up easily in connection with an R&S TS-PTRF. The Atmel AT25160 module is cut out for this purpose, a 16 kbit (2 kbyte) EEPROM for SPI. In this way, all the I/O ports remain free, only one SPI Chip Select signal of the R&S TS-PTRF is occupied.

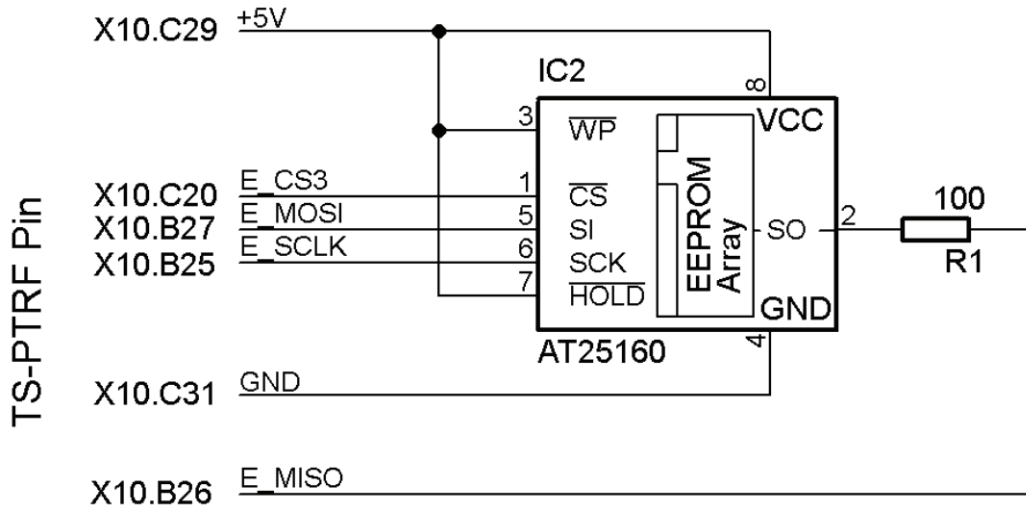

**Figure 7-2** System drawing of ATMEL AT25160

The EEPROM is written to and read using the following command.

```
rspio3b_SpiTransfer (..)
```

A simple protocol is required for this purpose (refer to the datasheet of the EEPROM used) .

The ChipSelect (in this example E\_CS3) is generated using the following command (only if the EEPROM is connected to an R&S TS-PTRF).

```
rspio3b_PtrfSelectPort (..)
```

Very different types of EEPROMs can be used. Due to its universal software, the R&S TS-PIO3B can serve all the SPI EEPROMs that can handle SPI mode 0.





## 8 Installation of the Modules

### 8.1 Installation of R&S TS-PIO3B and R&S TS-PTR

**CAUTION!**

Due to the front panel section of the R&S TS-PIO3B and R&S TS-PTR modules there is a risk of a short circuit with components underneath a long module in the slot directly to the right (viewed from the front). For this reason, the R&S TS-PIO3B and R&S TS-PTR modules must absolutely be screwed in place properly.

Proceed as follows to install the R&S TS-PIO3B or R&S TS-PTR modules:

- Shut down and switch off the R&S CompactTSVP / R&S PowerTSVP.
- Select an appropriate slot on the front. For more information on this topic, refer to the operating instructions of the „CompactTSVP R&S TS-PCA3“ or „PowerTSVP R&S TS-PWA3“ in the chapter „Permitted Module Configurations“
- Loosen the screws and remove the appropriate front panel section on the TSVP chassis.

**CAUTION!**

**Check the backplane plug-in connector for bent pins! Any pins that are bent must be straightened! Failure to observe this instruction may result in permanent damage to the backplane!**

- Push in the R&S TS-PIO3B or R&S TS-PTR module using moderate pressure.
- The retaining pins of the R&S TS-PIO3B or R&S TS-PTR module must be plugged into the right-hand hole.

**CAUTION!**

**When sliding in the R&S TS-PIO3B or R&S TS-PTR module, guide it with both your hands and cautiously push it into the backplane connectors.**

- The R&S TS-PIO3B or R&S TS-PTR module has been pushed in

**Installation of the Modules**

properly when a definite stop can be felt. Screw the upper and lower screws to the front panel of the module.

Proceed as follows to remove the R&S TS-PIO3B or R&S TS-PTR modules:

- Remove the screws at the top and bottom of the front panel of the R&S TS-PIO3B or R&S TS-PTR module.
- Use a tool (e.g. pliers or a hook) to pull the cord.

**WARNING!**

The R&S TS-PIO3B module is plugged especially tightly into slots 3 – 14 of the CompactTSVP. Caution! Do not jerk to pull it out. To prevent injuries, it is recommended to wear gloves.

**8.2 Installation of the R&S TS-PRIO4**

Proceed as follows to install the R&S TS-PRIO4 module:

- A prerequisite is that the R&S TS-PTR or R&S TS-PIO3B module has been installed.
- Select the corresponding rear I/O slot for the R&S TS-PTR or R&S TS-PIO3B module.
- Loosen the screws and remove the appropriate front panel section from the TSVP chassis.

**CAUTION!**

Check the backplane plug-in connector for bent pins! Any pins that are bent must be straightened! Failure to observe this instruction may result in permanent damage to the backplane!

- Push in the R&S TS-PRIO4 module using moderate force.

**CAUTION!**

When sliding in the R&S TS-PRIO4 module, it must be guided with both your hands and carefully pushed into the backplane connector.

- The R&S TS-PRIO4 module must be pushed in especially careful-

ly to ensure that the connector is properly inserted into guide of the socket opening in the backplane. The connector must not be misaligned when inserted. The short PCB guides alone do not ensure absolutely reliable guiding.

- The R&S TS-PRIO4 module has been inserted properly when a definite stop can be felt.
- Tighten the two fastening screws on the front panel of the R&S TS-PRIO4 module.

### 8.3 Installation of the R&S TS-PTRF

Proceed as follows to install the R&S TS-PTRF module:

- Shut down and switch off the R&S CompactTSVP / R&S PowerTSVP.
- Select the corresponding R&S TS-PIO3B or R&S TS-PTR module.
- Ensure that the removal cord of the R&S TS-PIO3B or R&S TS-PTR is not between the connectors.
- Push in the R&S TS-PTRF module using moderate force.
- The upper retaining pin of the R&S TS-PTRF module must be inserted into the right-hand hole, the lower retaining pin must be inserted into the left-hand hole of the TSVP chassis.



#### **CAUTION!**

**When sliding in the R&S TS-PTRF module, it must be exactly aligned. Guide rails have not been provided in the front area.**

- The R&S TS-PTRF module has been inserted properly when a definite stop can be felt.
- Tighten the upper and lower screws on the front panel of the R&S TS-PTRF module.



## **8.4 Installation of the R&S TS-PXM1**

Proceed as follows to install the R&S TS-PXM1 module:

- Shut down and switch off the R&S CompactTSVP / R&S PowerTSVP.
- Select an appropriate slot on the front.
- Plug the cable into the R&S TS-PXM1 and into the selected port of the R&S TS-PTRF.
- Place the R&S TS-PXM1 module into the locating hole. The upper retaining pin of the plug-in module must be inserted into the right-hand hole, while the lower retaining pin must be inserted into the left-hand hole of the TSVP chassis.
- Tighten the upper and lower screws on the front panel of the R&S TS-PXM1 module.

## 9 Software

### 9.1 Driver Software

An VI-C driver is available for the functions of the R&S TS-PIO3B digital I/O module. The driver is part of the ROHDE & SCHWARZ GTSL software. All the functions of the driver are documented comprehensively in the online Help and in the LabWindows/CVI Function Panels. The following software modules are installed during driver installation:

Module	Path	Note
rspio3b.dll	<GTSL directory>\Bin	Driver
rspio3b.hlp	<GTSL directory>\Bin	Help file
rspio3b.fp	<GTSL directory>\Bin	LabWindows/CVI Function Panel file, function panels for the CVI development environment
rspio3b.sub	<GTSL directory>\Bin	LabWindows/CVI Attribute file. This file is required by several „Function Panels“.
rspio3b.lib	<GTSL directory>\Bin	Import library
rspio3b.h	<GTSL directory>\Include	Header file for the driver

**Table 9-1** Driver installation



**NOTE:**

The IVI and VISA libraries of National Instruments are required to be able to operate the driver.

## 9.2 Soft Panel

A soft panel is available for the R&S TS-PIO3B digital I/O module. The soft panel is based on the IVI driver and permits interactive operation of the module.

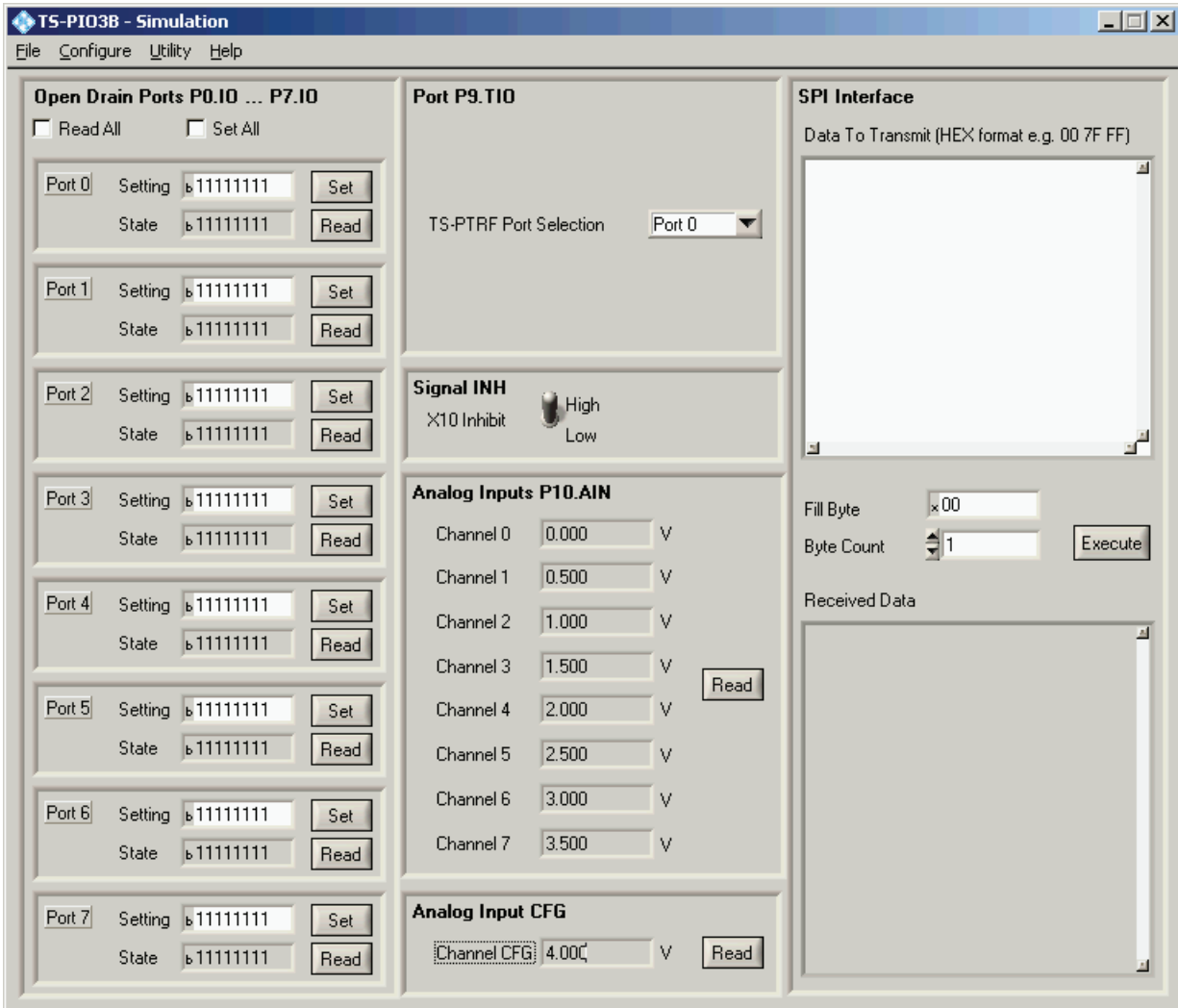

**Figure 9-1** Soft Panel of the R&S TS-PIO3B



**NOTE:**

The operation of the soft panel is described in chapter 13 of the „Software Description of the R&S GTSL“.

## 9.3 Sample Programs

### 9.3.1 Programming with GTSL Libraries

```
/*
Error handling is not considered in this sample in order to
keep it easy to read. The return status should be checked for
"errorOccured" after each library call.
```

The following configuration files are used in this example:

physical.ini

-----

```
[device->PIO3B_13]
Description = "TS-PIO3B, Digital IO Module, Slot 13"
Type       = PIO3B
ResourceDesc = CAN0::0::1::13
DriverDll   = rspio3b.dll
DriverPrefix = rspio3b
DriverOption = "Simulate=0,RangeCheck=1"
SFTDll      = sftmpio3b.dll
SFTPrefix   = SFTMPIO3B
```

Pio3bApplication.ini

-----

```
[bench->digitalTest]
Trace           = 0
Simulation      = 0
DIOdevice1     = device->PIO3B_13
DIOChannelTable = io_channel->digitalTest

[io_channel->digitalTest]
; TS-PIO3B channels at open drain port 0
CH_0_0 = PIO3B_13!p0io0
CH_0_1 = PIO3B_13!p0io1
CH_0_2 = PIO3B_13!p0io2
CH_0_3 = PIO3B_13!p0io3
CH_0_4 = PIO3B_13!p0io4
CH_0_5 = PIO3B_13!p0io5
CH_0_6 = PIO3B_13!p0io6
CH_0_7 = PIO3B_13!p0io7
; TS-PIO3B push/pull channels at port 9
CH_9_0 = PIO3B_13!p9tio0
CH_9_7 = PIO3B_13!p9tio7
; TS-PIO3B inhibit channel
Inh     = PIO3B_13!inh
```

```
*/
```



```
#include "resmgr.h"
#include "diomgr.h"

#define BUFF_SIZE 9

int main (int argc, char *argv[])
{
    long residDiomgr; /* resource ID for dio manager library */
    char resposeData[BUFF_SIZE];

    short errorOccurred = 0;
    long errorCode = 0;
    char errorMessage[GTSL_ERROR_BUFFER_SIZE] = "";

    /* load the physical and application configuration files */
    RESMGR_Setup (0, "physical.ini", "Pio3bApplication.ini",
                 &errorOccurred, &errorCode, errorMessage);

    /* initialize the dio manager library */
    DIOMGR_Setup (0, "bench->digitalTest", &residDiomgr,
                 &errorOccurred, &errorCode, errorMessage);

    /* reset CH_0_0 */
    DIOMGR_PortStimulus (0, residDiomgr, "CH_0_0=0",
                        &errorOccurred, &errorCode, errorMessage);

    /* read state of CH_0_0 to CH_0_7 */
    DIOMGR_PortResponse (0, residDiomgr,
                        "CH_0_7=X, CH_0_6=X, CH_0_5=X, CH_0_4=X, "
                        "CH_0_3=X, CH_0_2=X, CH_0_1=X, CH_0_0=X",
                        BUFF_SIZE, resposeData, VI_NULL, VI_NULL,
                        &errorOccurred, &errorCode, errorMessage);

    /* reset CH_0_3 */
    DIOMGR_PortStimulus (0, residDiomgr, "CH_0_3=0",
                        &errorOccurred, &errorCode, errorMessage);

    /* read state of CH_0_0 to CH_0_7 */
    DIOMGR_PortResponse (0, residDiomgr,
                        "CH_0_7=X, CH_0_6=X, CH_0_5=X, CH_0_4=X, "
                        "CH_0_3=X, CH_0_2=X, CH_0_1=X, CH_0_0=X",
                        BUFF_SIZE, resposeData, VI_NULL, VI_NULL,
                        &errorOccurred, &errorCode, errorMessage);

    /* set CH_0_0 and CH_0_3 */
    DIOMGR_PortStimulus ( 0, residDiomgr, "CH_0_0=1, CH_0_3=1",
                        &errorOccurred, &errorCode, errorMessage);
}
```



```
/* read state of CH_0_0 to CH_0_7 */
DIOMGR_PortResponse (0, residDiomgr,
    "CH_0_7=X, CH_0_6=X, CH_0_5=X, CH_0_4=X,"
    "CH_0_3=X, CH_0_2=X, CH_0_1=X, CH_0_0=X",
    BUFF_SIZE, resposeData, VI_NULL, VI_NULL,
    &errorOccurred, &errorCode, errorMessage);

/* reset inhibit channel INH */
DIOMGR_PortStimulus (0, residDiomgr, "INH=0",
    &errorOccurred, &errorCode, errorMessage);

/* set inhibit channel INH */
DIOMGR_PortStimulus (0, residDiomgr, "INH=1",
    &errorOccurred, &errorCode, errorMessage);

/* close the dio manager library */
DIOMGR_Cleanup (0, residDiomgr,
    &errorOccurred, &errorCode, errorMessage);

/* close resource manager library */
RESMGR_Cleanup (0, &errorOccurred, &errorCode, errorMessage);

return 0;
}
```



## 9.4 Programming with Device Drivers

```
/*
  Error handling is not considered in this sample in order to
  keep it easy to read. The return status should be checked for
  VI_SUCCESS after each driver call.
*/

#include "rspio3b.h"

#define  BUFF_SIZE      16

static ViChar txBuff[BUFF_SIZE];
static ViChar rxBuff[BUFF_SIZE];

int main (int argc, char *argv[])
{
  ViSession vi;
  ViStatus  status;
  ViUInt8   portVal;

  /*
   open a session to the device driver. The resource descriptor
   depends on the slot number of the module and must be adapted
   to the target system.
  */
  status = rspio3b_InitWithOptions ("CAN0::0::2::4::INSTR",
                                    VI_TRUE,
                                    VI_TRUE,
                                    "Simulate=0,RangeCheck=1",
                                    & vi);

  /* set port 0 bit 0 to active low */
  status = rspio3b_SetPort (vi, RSPIO3B_DIG_PORT_0, 0x01, 0x00);

  /* read port 0 */
  status = rspio3b_ReadPort (vi, RSPIO3B_DIG_PORT_0, & portVal);

  /* set port 0 bit 3 to active low */
  status = rspio3b_SetPort (vi, RSPIO3B_DIG_PORT_0, 0x04, 0x00);

  /* read port 0 */
  status = rspio3b_ReadPort (vi, RSPIO3B_DIG_PORT_0, & portVal);

  /* set all bits of port 0 to active high */
  status = rspio3b_SetPort (vi, RSPIO3B_DIG_PORT_0, 0xFF, 0xFF);

  /* read port 0 */
  status = rspio3b_ReadPort (vi, RSPIO3B_DIG_PORT_0, & portVal);

  /* set signale INH to low */
  status = rspio3b_SetInhibit (vi, VI_FALSE);
}
```



```
/* set signal INH to high again */
status = rspio3b_SetInhibit (vi, VI_TRUE);

/* SPI transfer to R&S TS-PTRF port 3; select port */
status = rspio3b_PtrfSelectPort (vi, RSPIO3B_VAL_PTRF_PORT_3);

/* start SPI transfer; store received data in s_rxBuffer */
txBuff[0] = 0x03;
txBuff[1] = 0x00;
txBuff[2] = 0x00;

status = rspio3b_SpiTransfer (vi, txBuff, rxBuff, BUFF_SIZE);

/* reset module, close the driver session */
status = rspio3b_close (vi);

return 0;
}
```



**ROHDE & SCHWARZ**

**Software**

## 10 Self-Test

The modules described in the present manual feature the self-test capabilities listed in the table below.

	R&S TS-PIO3B	R&S TS-PTRF	R&S TS-PRIO4	R&S TS-PXM1	R&S TS-PTR
LED test	no	yes	no	yes	no
Automatic detection	yes	yes <sup>(1)</sup>	yes <sup>(1)</sup>	yes	no
Fuse test	yes	no	no	no	no

**Table 10-1** Self-test capabilities of the modules

<sup>(1)</sup>: only in combination with R&S TS-PIO3B

### 10.1 LED test

After the system is switched on, all the LEDs of the module will briefly light up. This indicates that the required power supply has been applied and all LEDs are in proper order. For details on the LED indicators, please refer to the description in the respective chapter of the module entitled „Indicators“.

### 10.2 Automatic Detection

Within the scope of the TSVP self-test and upon the start of the TSVP panel, the modules are identified. The above table lists the modules that can be detected automatically when connected to an R&S TS-PIO3B.

#### NOTE:



**You can find information about starting the self-test and the order of required work steps as well as a detailed description of parameters and sequences that are tested in the R&S CompactTSVP / R&SPower TSVP Service Manual.**



### 10.3 Fuse test

During this test the fuses in the voltage supply lines +12 V, +5 V, +3.3 V (AUX1) and -12 V (AUX2) are checked. All voltages are applied via a negatively biased summing amplifier to the common input of the A/D converter.

If, for example, the AUX1 und AUX2 lines are activated via the jumpers X2 and X3 (default setting) and no voltages are applied on both AUX lines, a A/D converter voltage of 1.0 V is expected. This value must be within the limits of 0.875 and 1.125 V. A fuse defect changes this value by at least 250 mV and can therefore be detected.

Changing the default jumper settings X2 and X3 or applying an external voltage on the AUX lines by the user, changes the expected A/D converter voltage. In this case the limits against which the value shall be compared, can be manually specified by the user in the file `physical.ini` within the relevant section for the module R&S TS-PIO3B.  
Example:

```
SFTFuseTest = 1.2,0.8
```

```
(SFTFuseTest = <upper limit/V>,<lower limit/V>)
```

# 11 Specifications

**NOTE:**

Technical data of the modules are specified in the corresponding data sheet.

If there are discrepancies between the information in this operating manual and the values of the data sheet, the values of the data sheet take precedence.

**Order information:**

<b>Item</b>	<b>Type:</b>	<b>Order No.</b>
Digital I/O Module	R&S TS-PIO3B	1512.4407.02
Signal Transmission Module	R&S TS-PTR	1512.4407.03
Port Transmission Module	R&S TS-PTRF	1512.3800.02
Rear Transmission Module	R&S TS-PRIO4	1510.8005.02
Switching Extension Module	R&S TS-PXM1	1512.4007.02



**ROHDE & SCHWARZ**

**Specifications**